

ES-CS1325

STICK WINDOW WALL



HSEQ REGULATIONS

Read all instructions carefully before attempting this procedure. If you have any questions about your ability to complete this procedure, contact ESWINDOWS for further direction.

If the need of swing stages is required for installation, the HSEQ inspector must approve the permissions.

- Wear the necessary personal protective equipment for product installation.
- Take safety precautions when performing the activity.
- Please follow the steps and make sure you have appropriate personal protective equipment and follow the rules established by the guidance for working at height, if required to do so.

INTRODUCTION





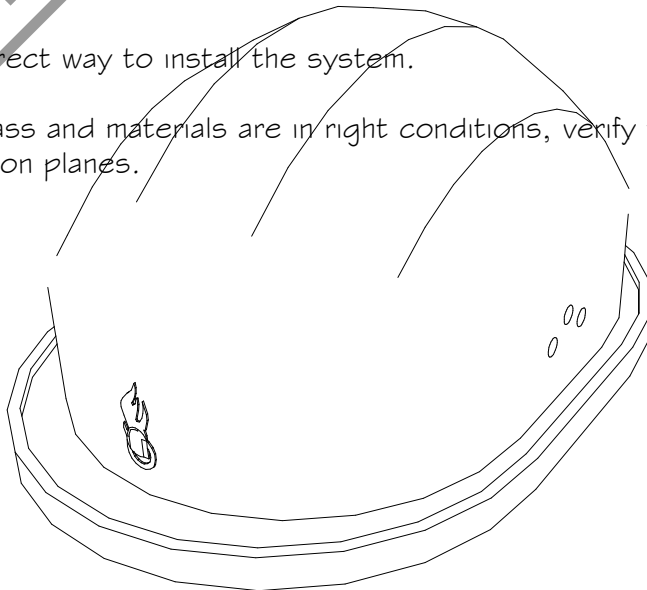

ES-CS1325 is a window wall stick system.

This guide illustrates step by step the correct way to install the system.

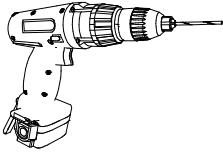
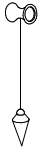
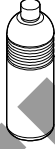
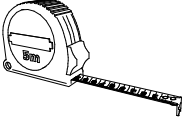

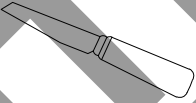
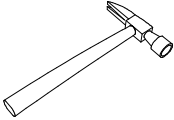
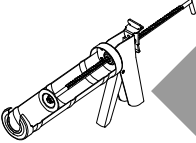
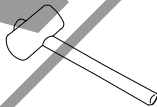
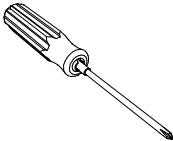
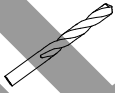
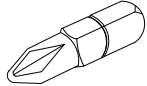
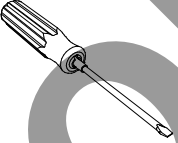
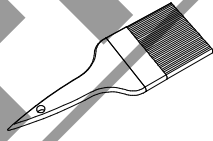
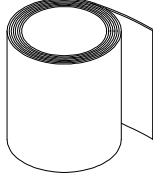
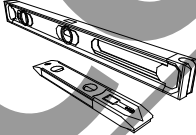
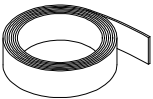
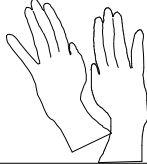

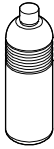





Prior to installation check that all parts, glass and materials are in right conditions, verify that the quantities and descriptions match production planes.















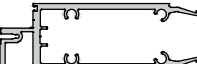
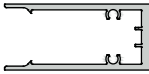



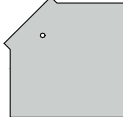

TOOLS AND SUPPLIES REQUIRED FOR INSTALLATION











DETAIL	DESCRIPTION	DETAIL	DESCRIPTION	DETAIL	DESCRIPTION
	Drill		Plumb		Thinner
	Tape Measure		Thread		Knife
	Hammer		Silicone Gun		Rubber Hammer
	Phillips Screwdriver		Bits for Concrete		Points
	Slot Screwdriver		Brush		Clean rag
	Level		Masking tape		Gloves
	High impact plastic shims		Isopropyl Alcohol		Safety Glasses

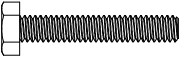



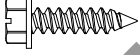



INTRODUCTION AND HSEQ	1
TOOLS AND SUPPLIES REQUIRED FOR INSTALLATION	2
PARTS REQUIRED FOR INSTALLATIONS	4-7
STEP 1	
Inspection and verification.....	8
STEP 2	
Verify anchor types.....	9
STEP 3	
Verify fabrications.....	10-17
STEP 4	
Shear block and corner angle installation.....	18
STEP 5	
Install steel reinforcement.....	19
STEP 6	
Anchors installation.....	20
STEP 7	
Installation of horizontals.....	21-22
STEP 8	
Install anchor screws and horizontal covers.....	23-24
STEP 9	
Install corner adaptor.....	25
STEP 10	
Install pocket filler.....	26
STEP 11	
Glazing.....	27-36
STEP 10	
Seal perimeter.....	37
REVISIONS	



PARTS REQUIRED FOR INSTALLATION		
PART	DETAILS	DESCRIPTION
ES-7525-003		CAPTURED HORIZONTAL
ES-CS1325-002		OPEN SSG HORIZONTAL
ES-CS1325-011		SILL/HEAD
ES-7525-005		SNAP INTERIOR COVER
ES-CS1325-052		SNAP INTERIOR COVER
ES-CS1325-004		MULLION FEMALE
ES-CS1325-005		MULLION MALE
ES-6025-008		PRESSURE PLATE
ES-6025-009		STANDARD COVER
ES-6025-015		90° ADAPTER
ES-CS1325-008		SSG MULLION MALE

PARTS REQUIRED FOR INSTALLATION		
PART	DETAILS	DESCRIPTION
ES-CS1325-051		CORNER COVER
ES-CS1325-402		ANCHOR
ES-CS1325-402		U ANCHOR
ES-7525-006		SHEAR BLOCK
ES-CS1325-006		HORIZONTAL SNAP FRONT
ES-CS1325-007		HORIZONTAL SNAP BACK
ES-6025-013		POCKET FILLER
ES-CS1325-011		HEAD/SILL
ES-6025-C02		MULLION END CAP
ES-CS1325-C01		CORNER MULLION END CAP

PARTS REQUIRED FOR INSTALLATION		
PART	DETAILS	DESCRIPTION
ES-6025-G01A		INTERIOR/EXTERIOR GASKETS
ES-6025-G02		ISOLATOR
ES-6025-G04 (TR-17883S)		SPACER © JAMBS FOR INSU-LAMINATED GLASS
ES-4520-B02A (TR-6371S)		SIDE BLOCK
80-356		SETTING BLOCK FOR INSU-LAMINATED GLASS
ES-6025-G06		EXTERIOR GASKET
1/2"		BACKER ROD BETWEEN CAPTURED MULLIONS
1/4"		BACKER ROD (UNDER GLASS © SSG HORIZONTALS)
3/8"		BACKER ROD (ONTO GLASS © SSG HORIZONTALS)
ES-6025-B10		JOINT PLUG FOR 15/16" GL.

PARTS REQUIRED FOR INSTALLATION		
PART	DETAILS	DESCRIPTION
3/4"		BACKER ROD BETWEEN SSG GLASS JOINTS
1/4"*1/4"		1/4*1/4 BLACK FOAM TAPE
1/4"-20x1 1/2"		FOR SHEAR BLOCK
#12 x 1" P.H		FOR CORNER ANGLE
#12 x 3/4" F.H		FOR SHEAR BLOCK
#10 x 1/2" F.H		FOR CORNER ANGLE
1/4" x 1"		FOR LOUVER, PRESSURE PLATE AND CORNER ADAPTOR
#8 x 1/2" P.H		FOR CORNER ADAPTOR
#8 x 1/2" F.H		FOR FIREWALL
3/8"-16x1 1/2"		FOR BACK AND FRONT SILL

PARTS REQUIRED FOR INSTALLATION		
PART	DETAILS	DESCRIPTION
1/4" x 3"		FOR REINFORCEMENT
1/4" - 20		FOR REINFORCEMENT
1/4"		FOR REINFORCEMENT 1/4" x 3"
3/8"		FOR HORIZONTAL SNAP 3/8"-16 x 1 1/2"
ES-6025-B05		SETTING BLOCK FOR LAMINATED GLASS
CRYLIC PSA FLB-22		CLEAR BUMPER W/A 0.5" x 2.5"
NS-25-G03		ISOLATOR GASKET
ANCHOR 1		STEEL ANCHOR FOR JAMB BY OTHERS

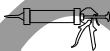
PARTS REQUIRED FOR INSTALLATION		
PART	DETAILS	DESCRIPTION
ANCHOR 2		STEEL ANCHOR FOR MULLION BY OTHERS
DC-995/795		STRUCTURAL SILICONE
DC-791		WEATHERPROOFING SEALANT



Check the technical manuals and guides by sealant manufacturers to apply silicone correctly.

STEP 1

INSPECTION AND VERIFICATION

- 1.1. The units, slabs, walls and other locations where the system will be installed, should be checked for the correct size as determined by dimensions listed in the architectural specifications and the shop drawings.
- 1.2. Check all the material upon arrival for quantity and damages.
- 1.3. Remove all materials that interfere with the proper installation of the unit.
- 1.4. If any irregularities are detected notify the general contractor.

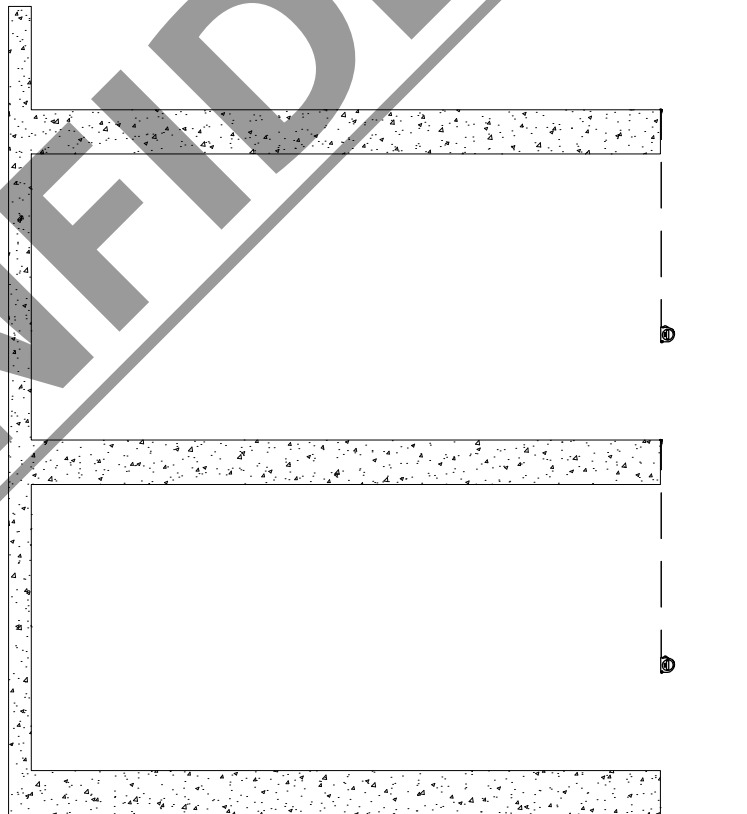

STEP 2

VERIFY ANCHOR TYPES:

2.1. The following detail illustrates the typical anchors for this system.



Verify shop drawings to identify the anchor types you will work with. Anchors may vary depending on the project requirements and anchors should be established by a qualified engineer.

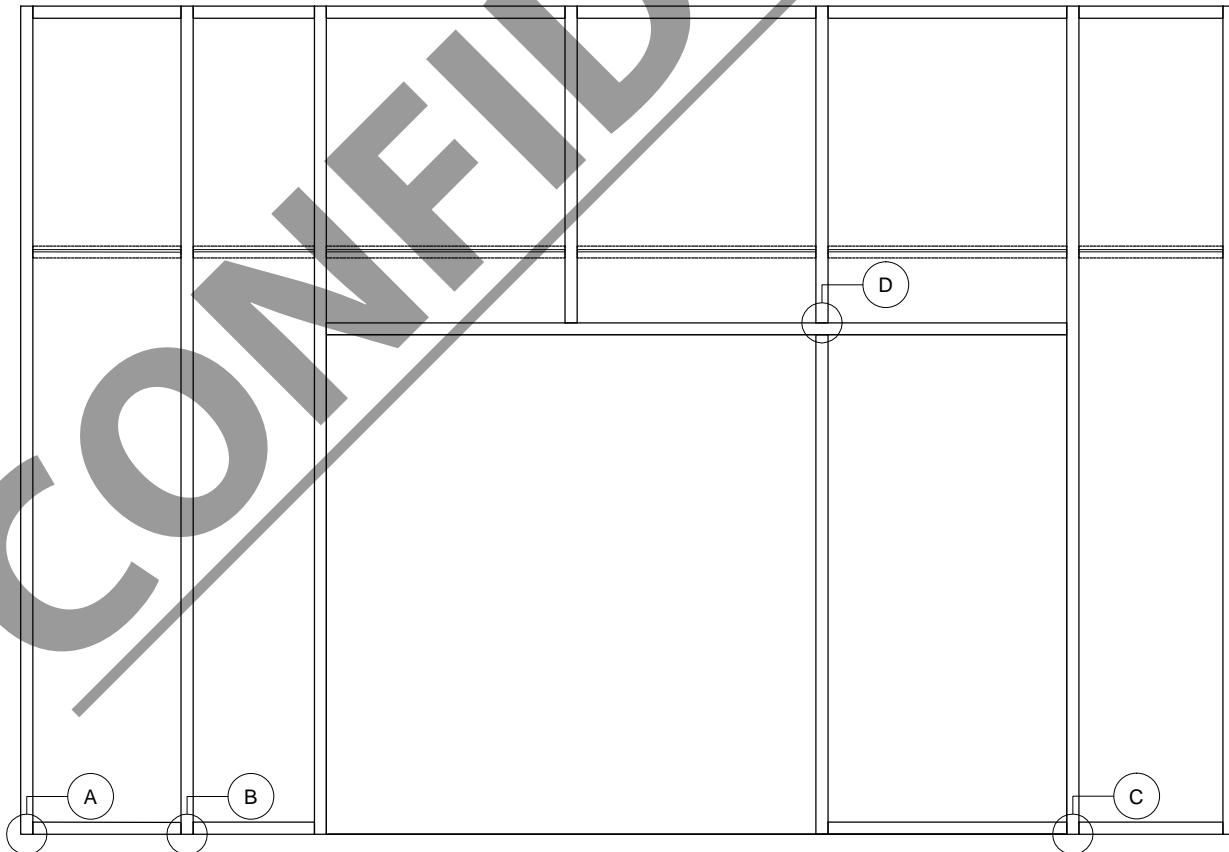
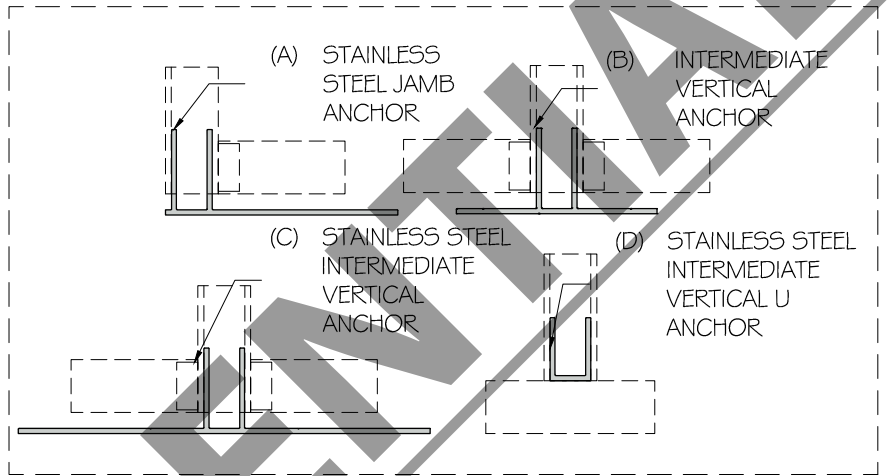

DETAIL 2.1

STEP 3

VERIFY FABRICATIONS:

FABRICATIONS FOR VERTICALS:

- 3.1. Prior to system installation, verify the verticals fabrications and shop drawings.
- 3.2. Verify jambs and mullions for shear block perforations. Check the shop drawings to determine the location of the shear blocks.



Verify verticals height match the height required in the shop drawings.



Shear blocks may arrived already installed. If so, adjust screws, if not follow step 4 for installation.



Optional steel reinforcement can be used depending on the structural requirements of the project.

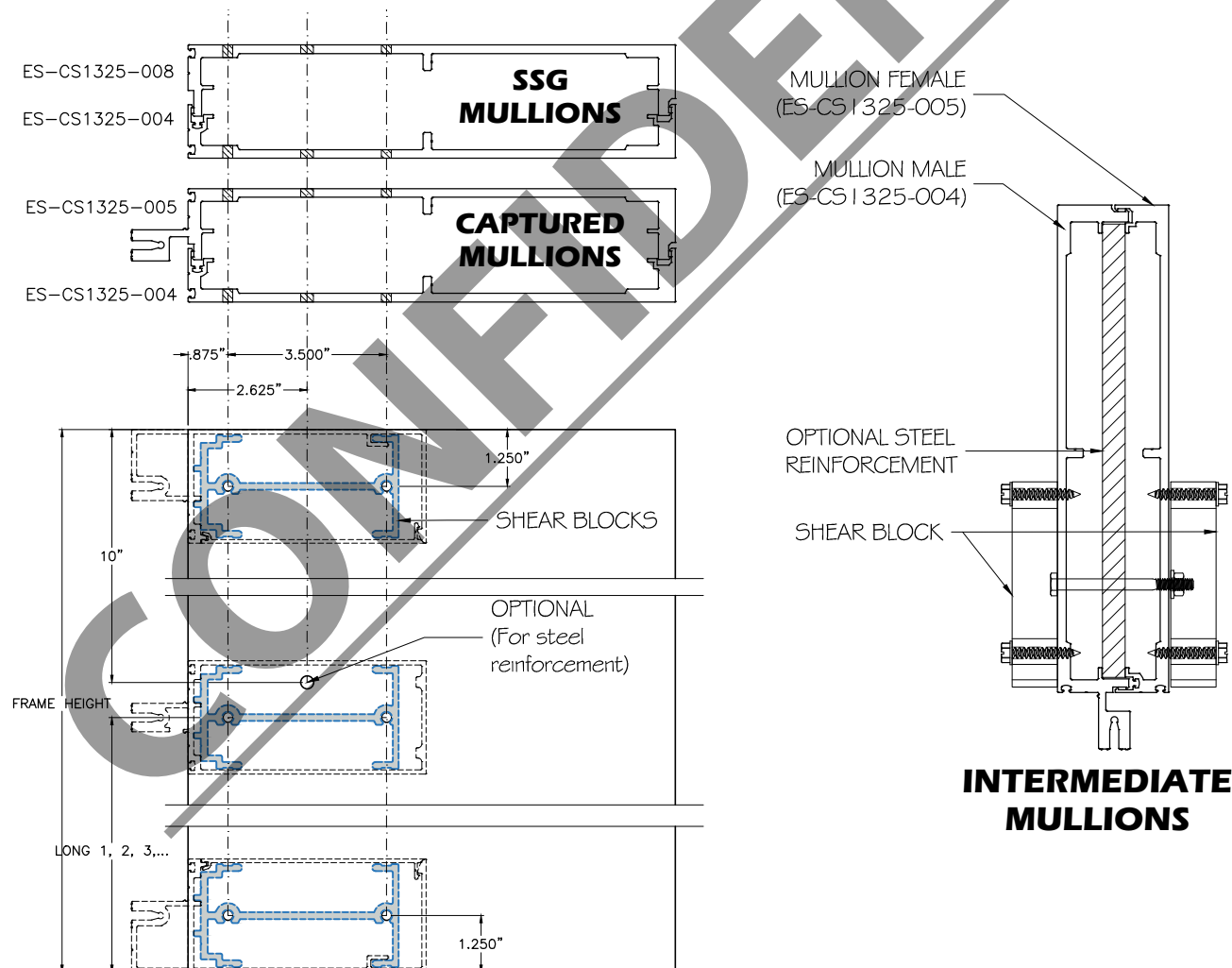

DETAIL 3.2

3.3. Verify mullions perforations for the back and front sill horizontal. Back and front sill horizontal must be installed to unsnapped mullions as shown in detail.

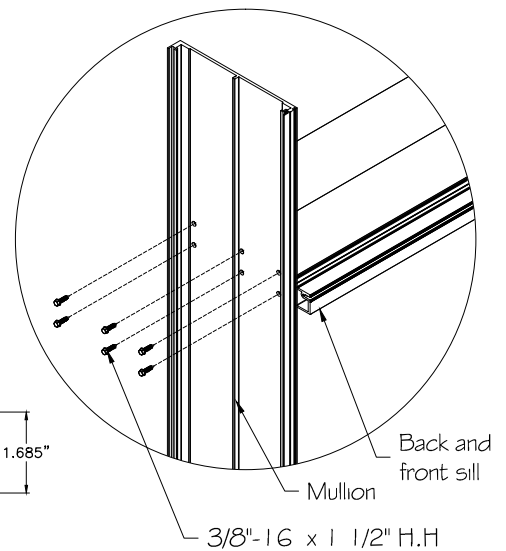
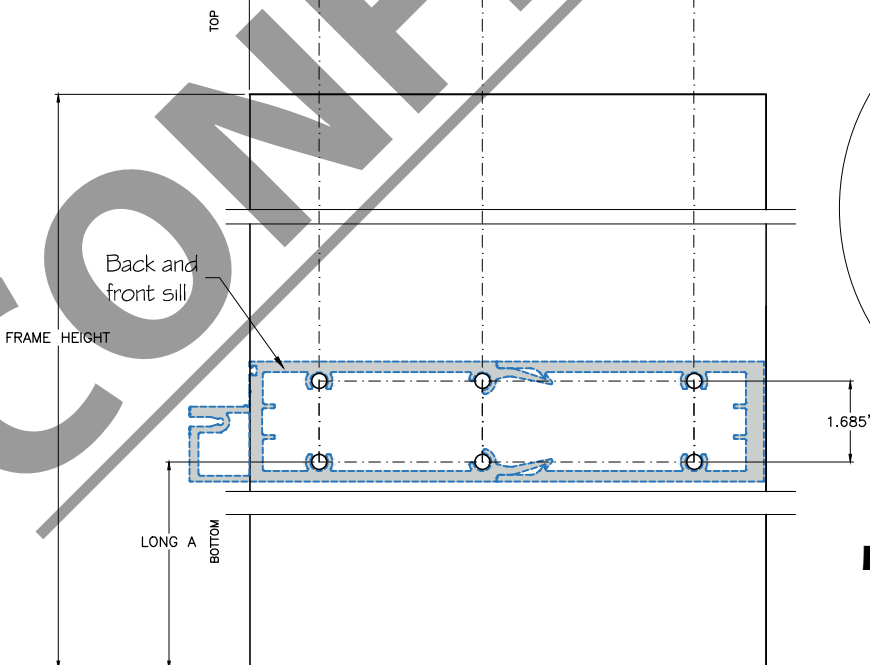
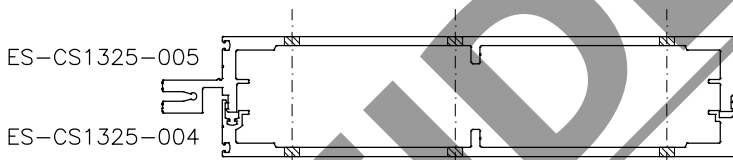
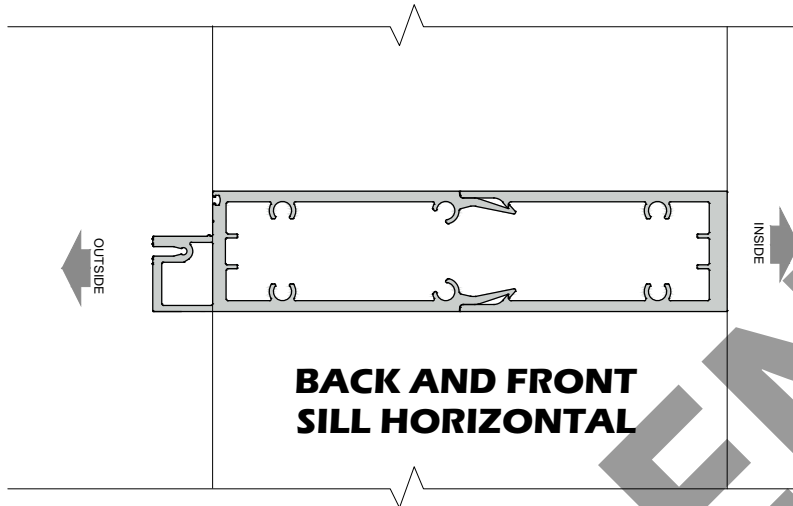

**BACK AND FRONT SILL
INSTALLATION**

DETAIL 3.3

3.4. Verify the corner vertical fabrications to install the corner angles. Verify shop drawings to determine the location of the corner angles and for the required length of the verticals.

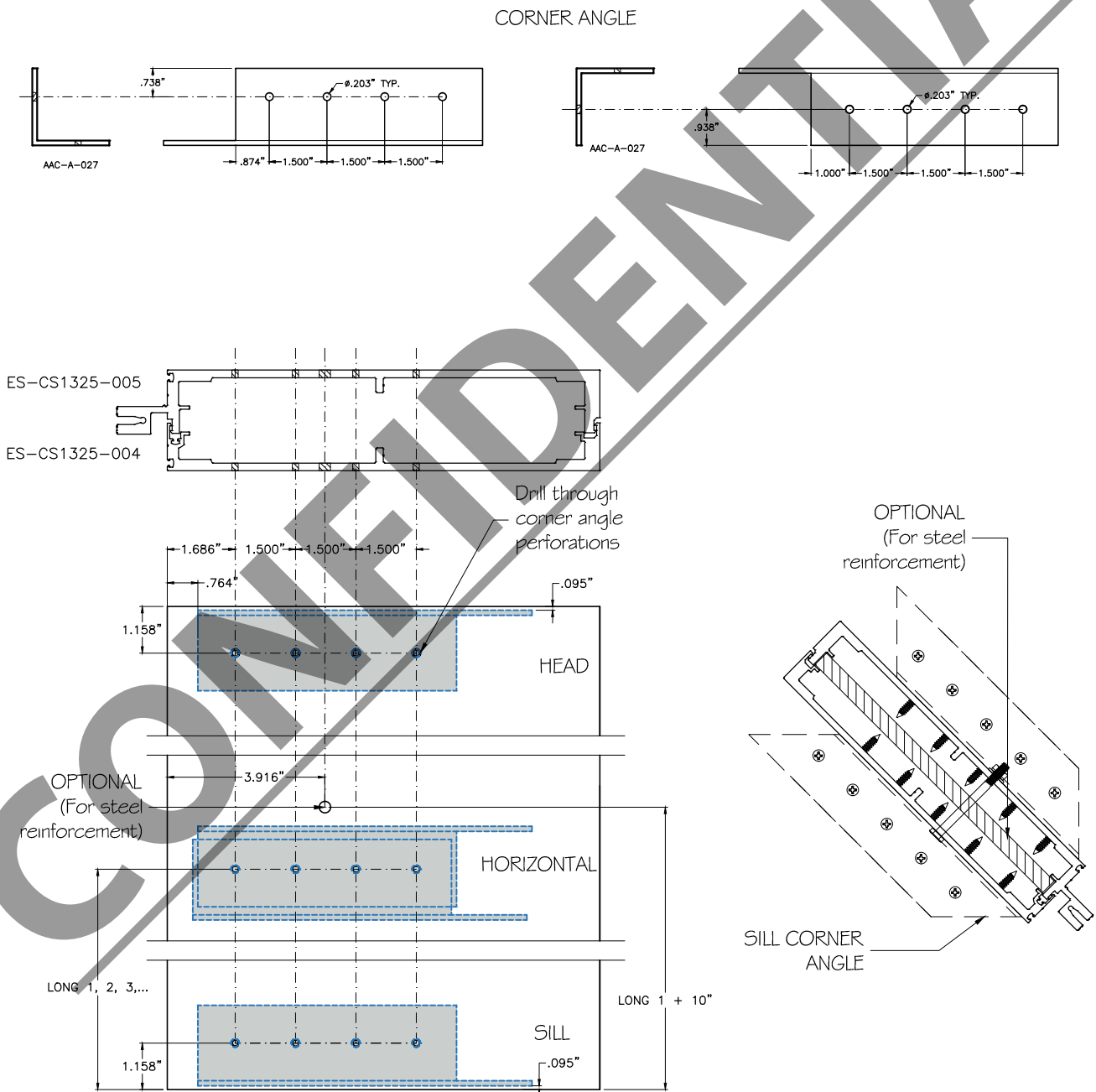

FABRICATIONS FOR HORIZONTALS:

3.5. Verify horizontals for the shear block perforations.

 Verify horizontals width match the width required in the shop drawings. Width it's expressed in terms of the D.L.O.

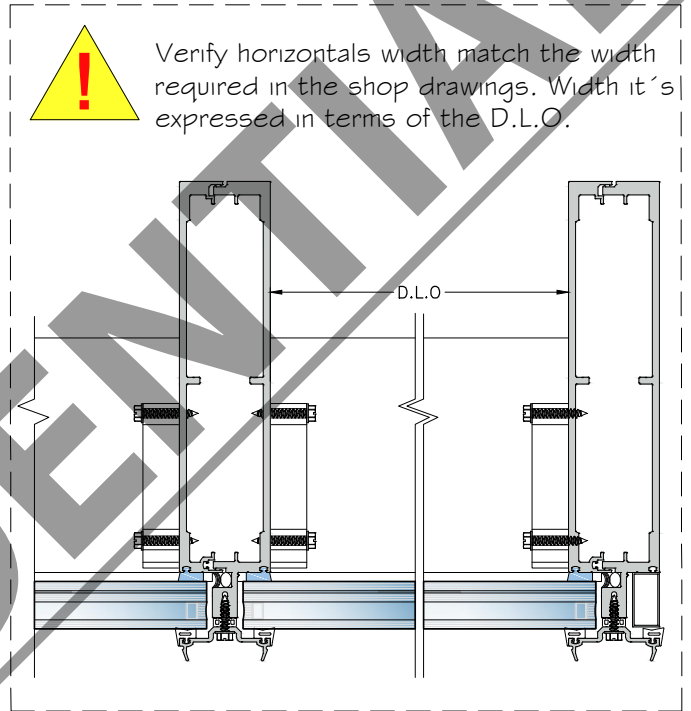
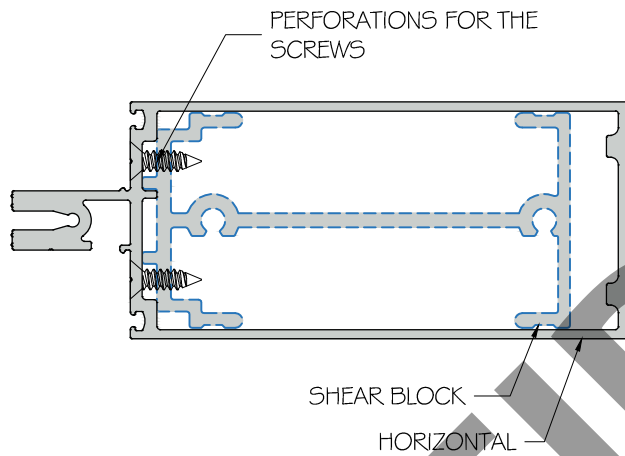

CLOSED HORIZONTAL **SSG OPEN HORIZONTAL**

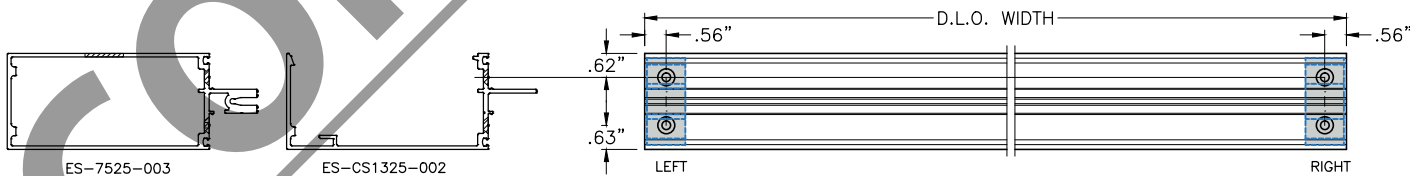

Detail 3.5

3.6. Verify the notches in the horizontals for the assembly with SSG verticals.

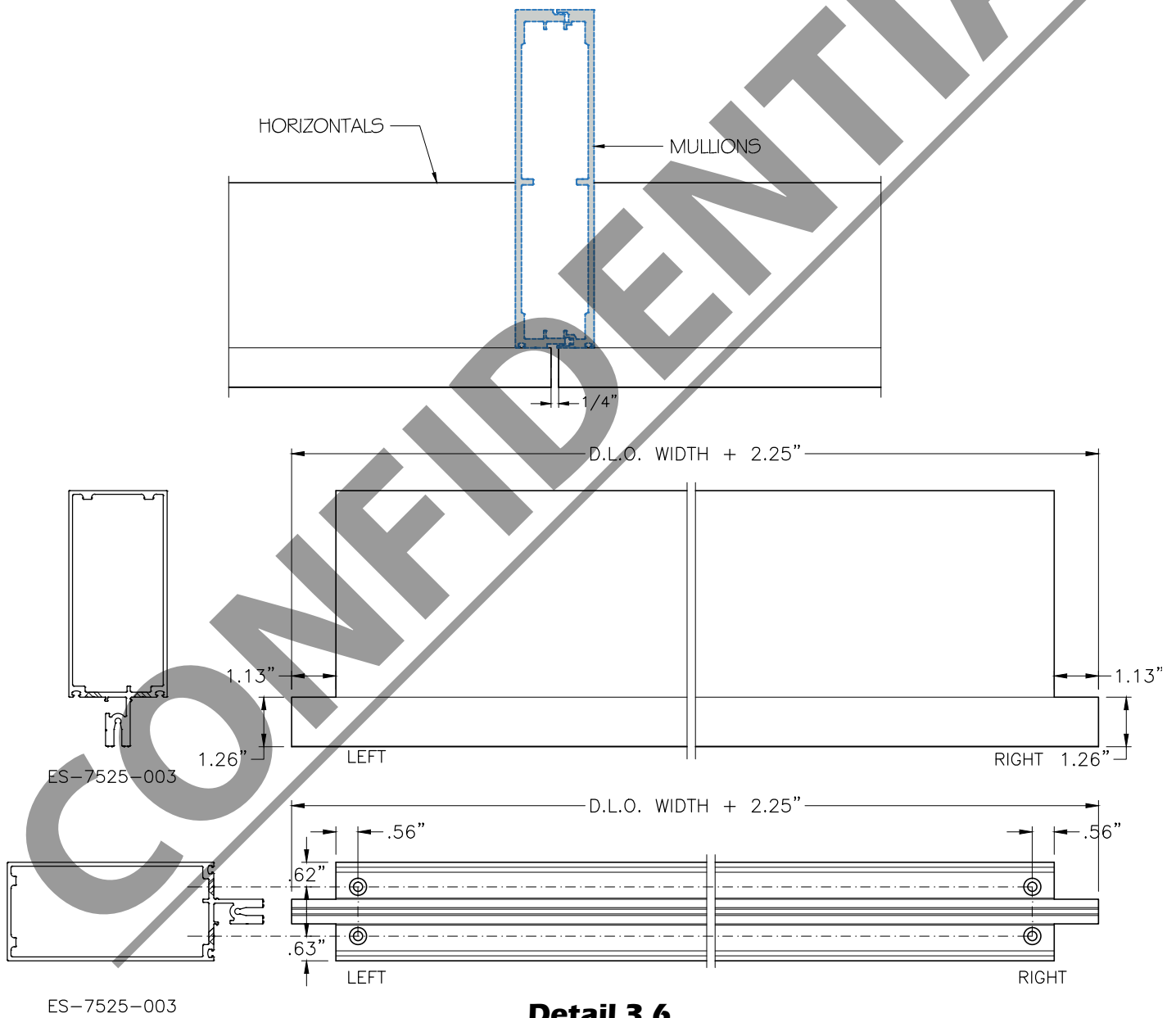

3.7. Verify the angle cut in corner horizontals.

3.8. Verify the perforations for the corner angle (Detail A) and the shear block (Detail B).

Closed horizontal



ES-7525-003

Detail B

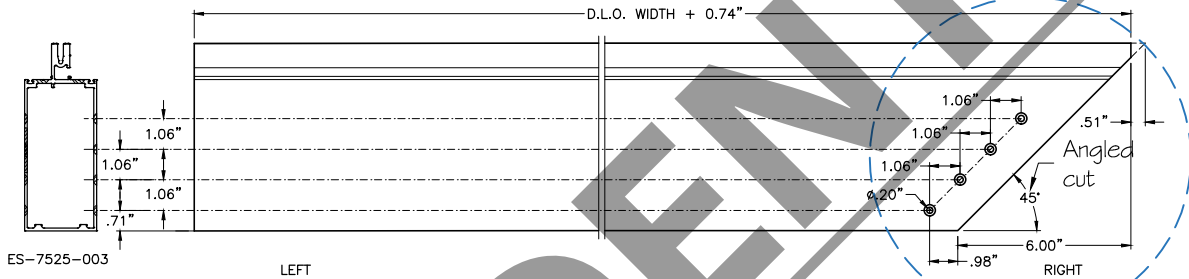

ES-7525-003

LEFT

RIGHT

Detail 3.7

Open horizontal

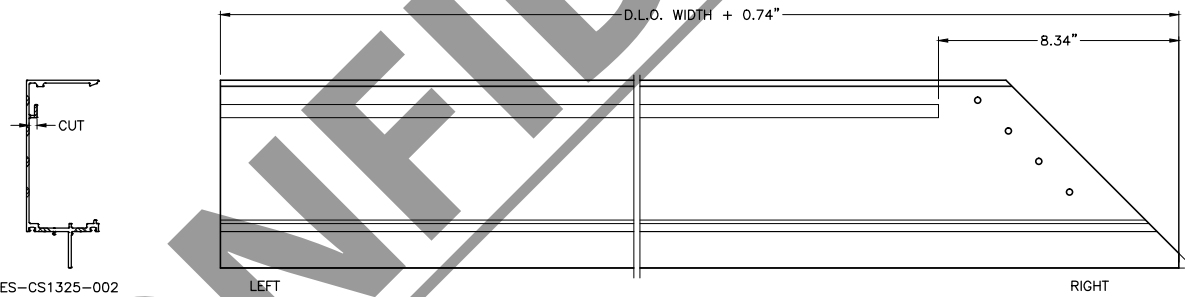

ES-CS1325-002

LEFT

RIGHT

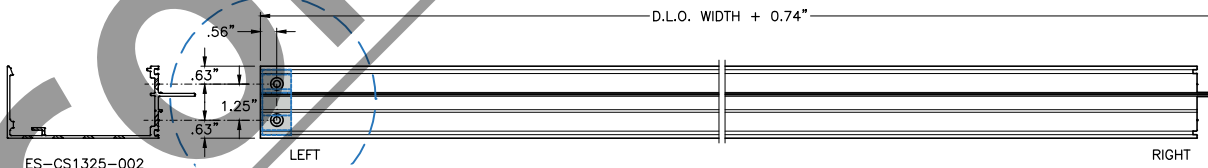

ES-CS1325-002

Detail B

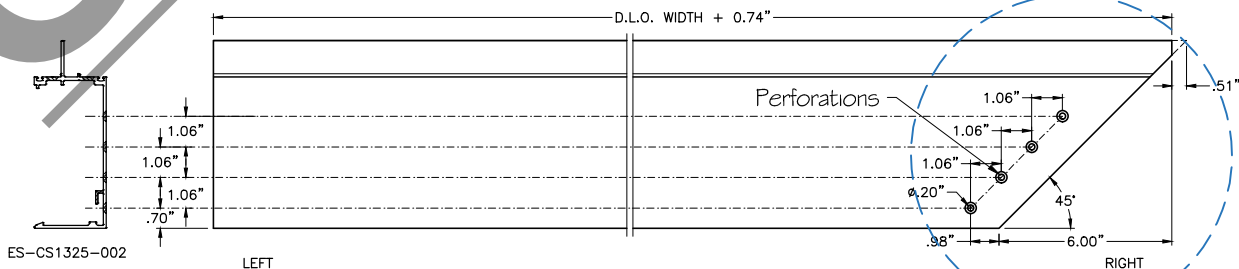

ES-CS1325-002

LEFT

RIGHT

Detail A

3.9. Verify the sill and head for the following fabrications:

- A. Anchor access holes (Detail A),
- B. Angled cut (Detail B),
- C. Shear block perforations (Detail C),
- D. Corner angle perforations (Detail D).

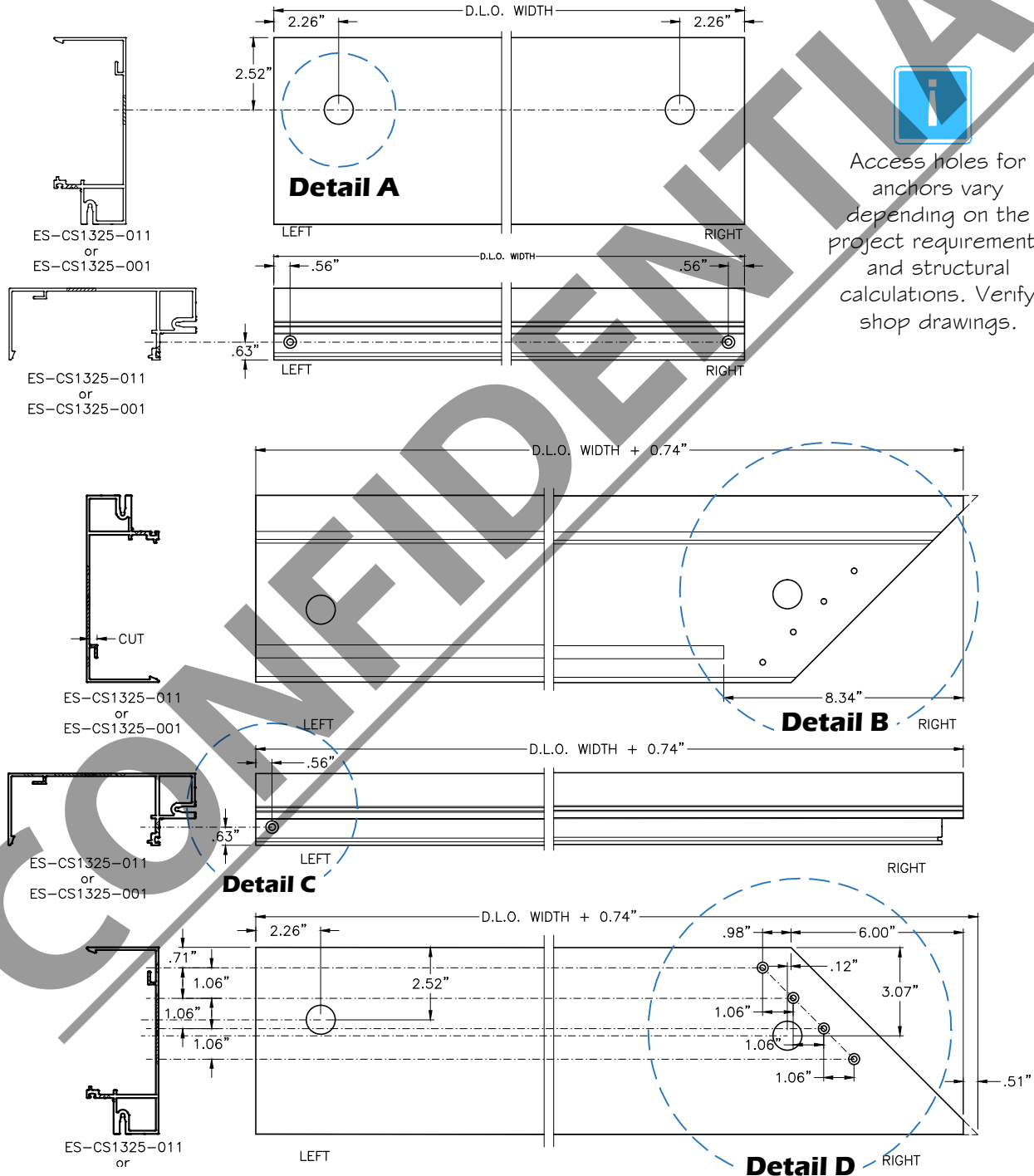

3.10. For SSG configurations verify the notch in the head and the sill for the assembly with the verticals.

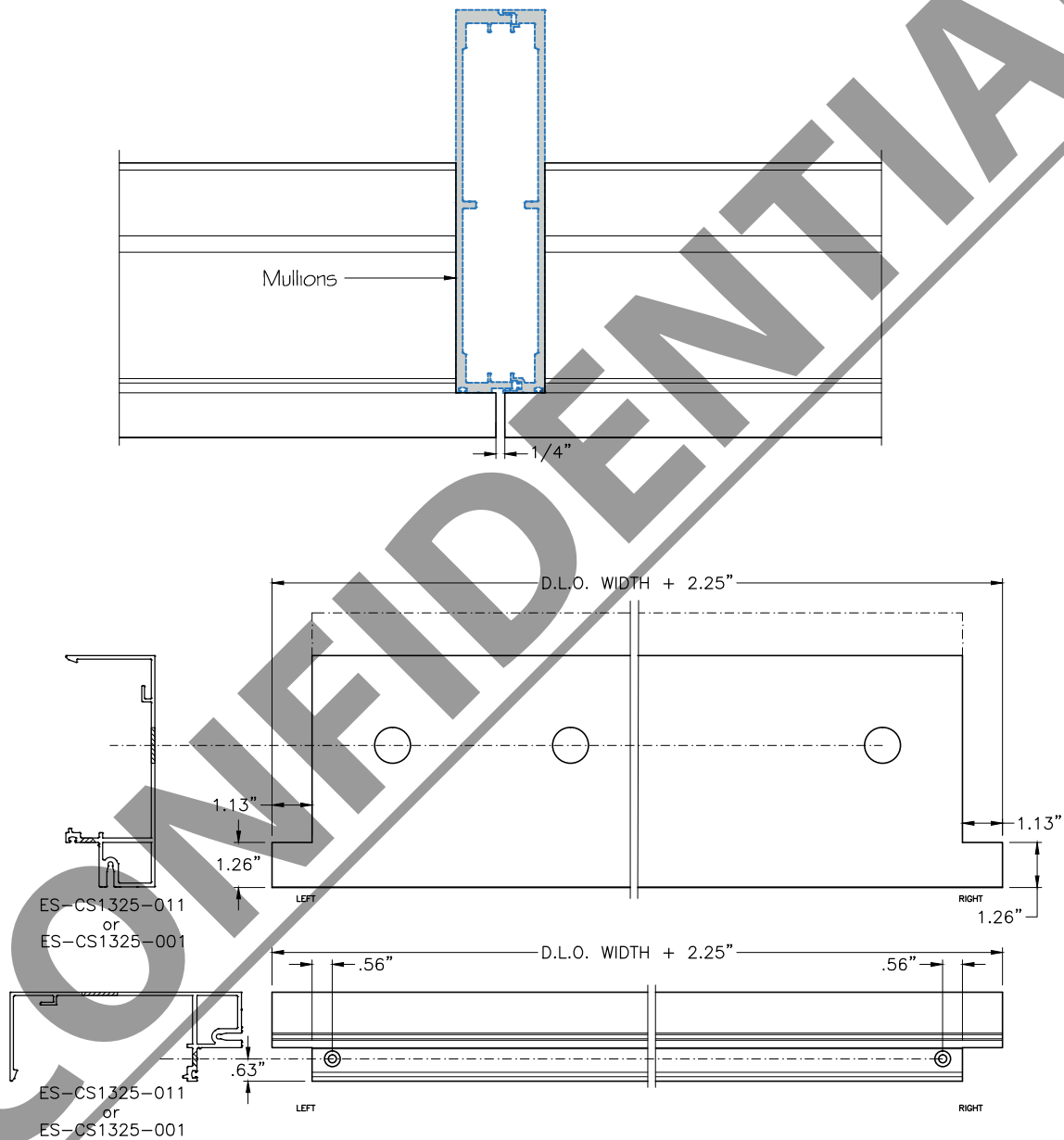

Detail 3.10

STEP 4

SHEAR BLOCK AND CORNER ANGLE INSTALLATION:

Shear blocks and corner angles are used to assemble horizontals to verticals:

4.1. Attach the shear block to the vertical with two screws as shown in detail 4.1.

4.2. For corner verticals install the corner angle. Verify the shop drawings to identify the corner angle reference to use and its location.

ES-7525-006
(SHEAR BLOCK)

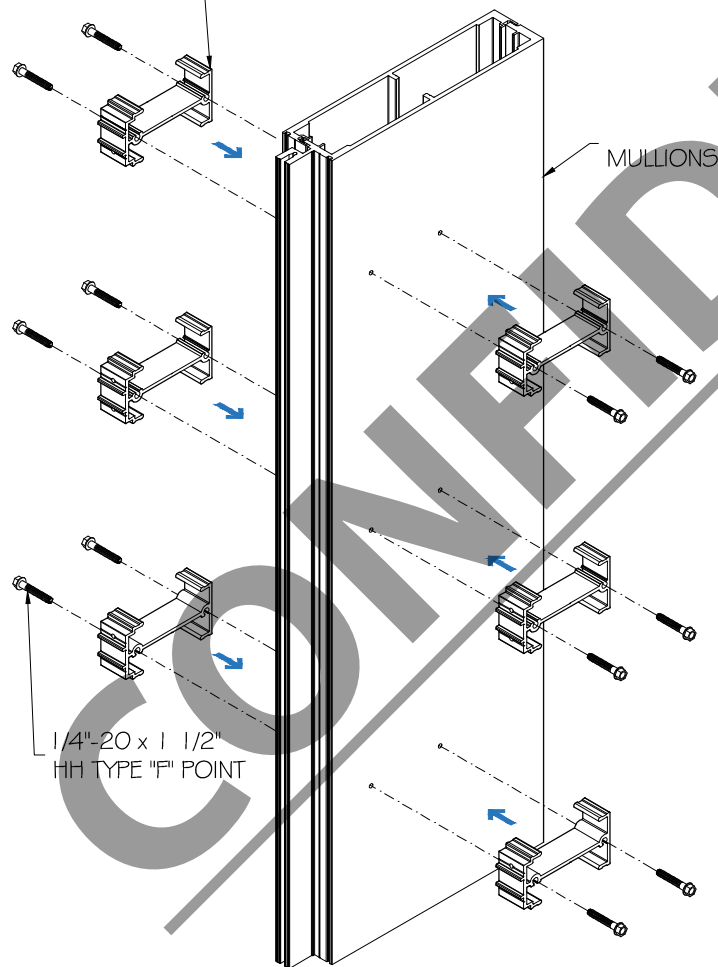

DETAIL 4.1

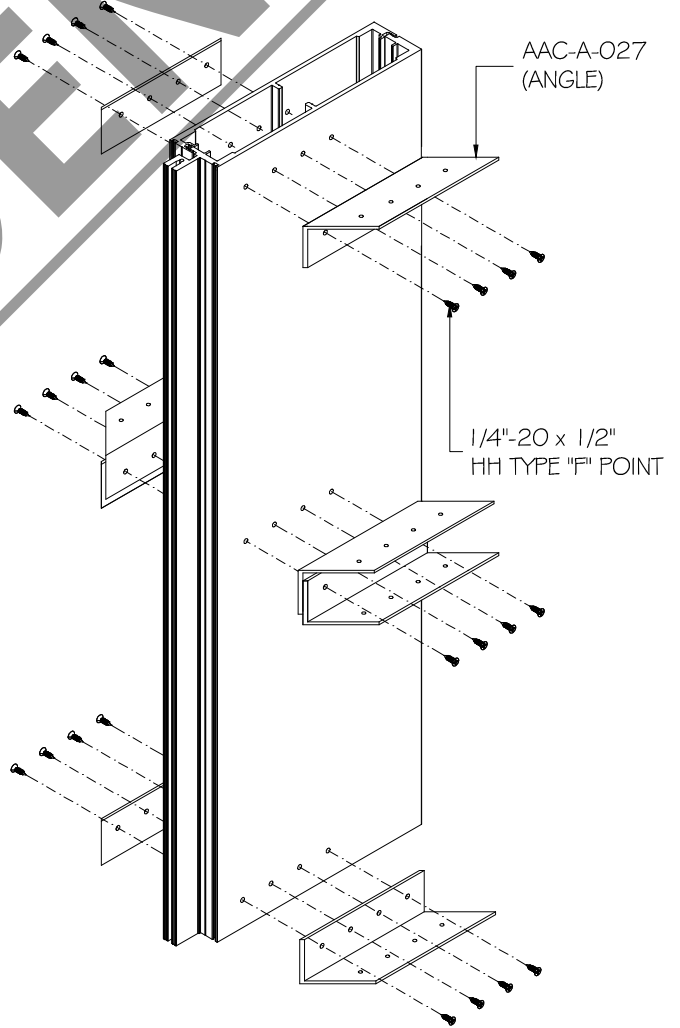

DETAIL 4.2

STEP 5

INSTALL STEEL REINFORCEMENT:

- 5.1. Verify the shop drawings to determine the location of reinforcements if required.
- 5.2. Install steel reinforcement and secure it with screw and the nut.

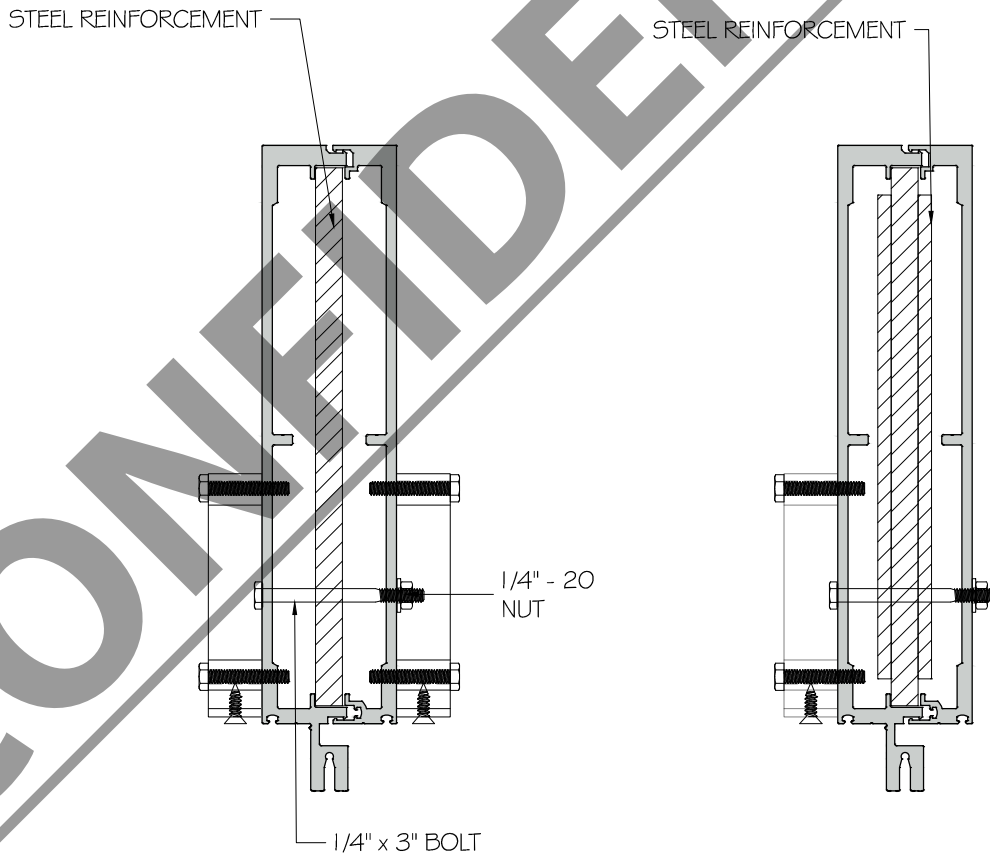

DETAIL 5.2

STEP 6

ANCHORS INSTALLATION:

- 6.1. Prior to installing anchors install the end caps at top and bottom of captured verticals as shown in detail. (Only if required in the shop drawings).
- 6.2. Caulk the joint between the end cap and the vertical.
- 6.3. Install the anchors. Verify the shop drawings to determine the type of anchor to use on each vertical.



Verify shop drawings to determine the anchor screws.

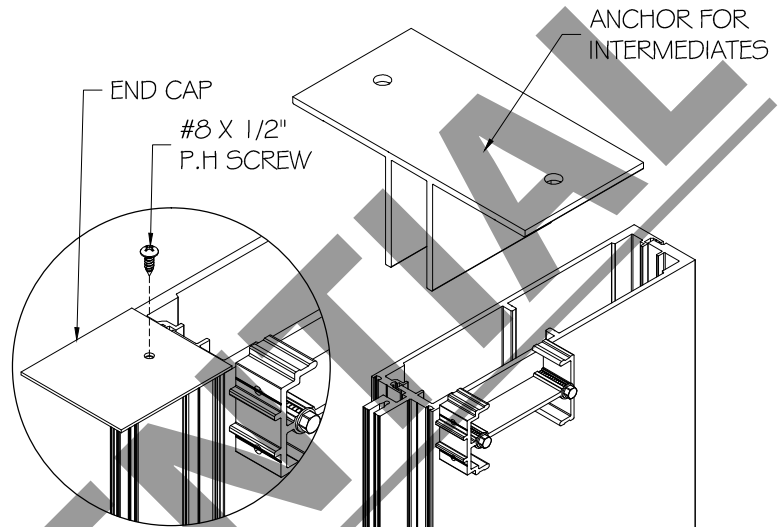

DETAIL 6.1

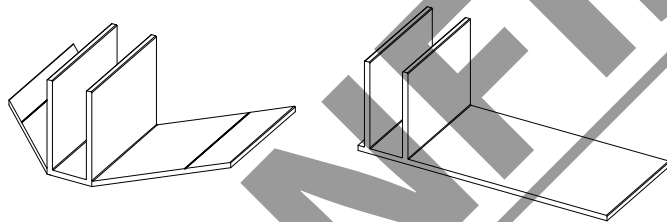

ANCHOR FOR CORNER MULLIONS

ANCHOR FOR JAMBS

U ANCHOR FOR VERTICALS

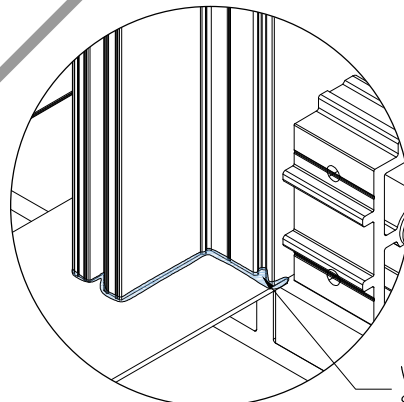

DETAIL 6.2

WEATHERPROOFING SILICONE D.C 791

Shim between the vertical and bottom anchors as required in shop drawings

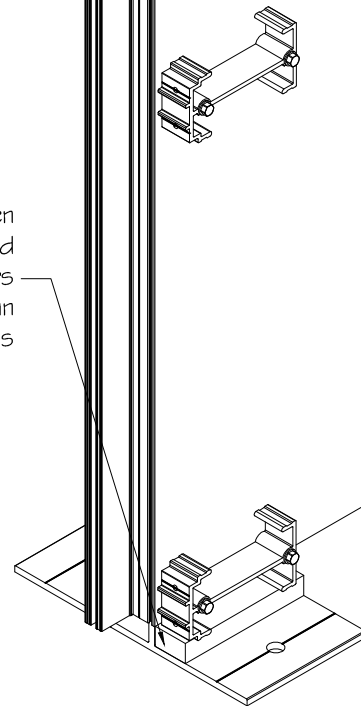

DETAIL 6.3

STEP 7

INSTALLATION OF HORIZONTALS:



Clean surfaces with isopropyl alcohol (50%) and the "two rag method" before applying silicone.

The profile surface must be clean and dry before applying the sealant. Apply required primer if necessary.

- 7.1. Prior to installing horizontals apply silicone D.C.791 around the end dam or corner angle where the horizontal will be located.
- 7.2. Install horizontals attaching them with screws to shear blocks/corner angle as shown in detail (seal the head of the screws).
- 7.3. Make sure that the horizontal perimeter is completely sealed and clean the excess of silicone.

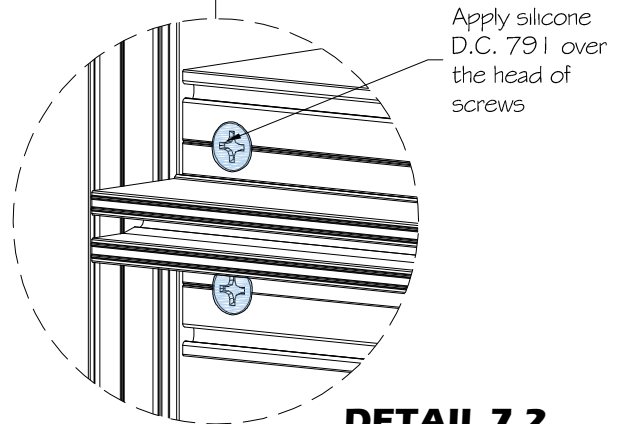
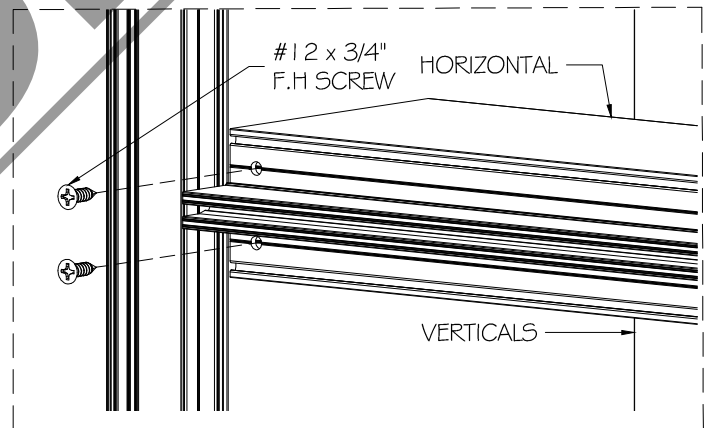
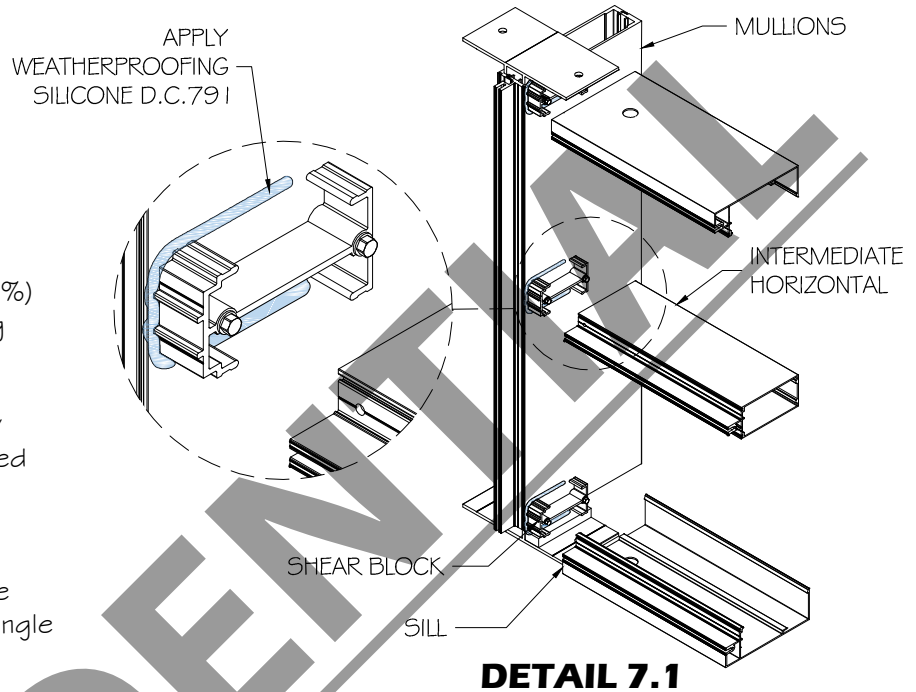

INSTALLATION OF CORNER HORIZONTALS:

7.4. Follow steps 7.1 to 7.3 to install corner horizontals.

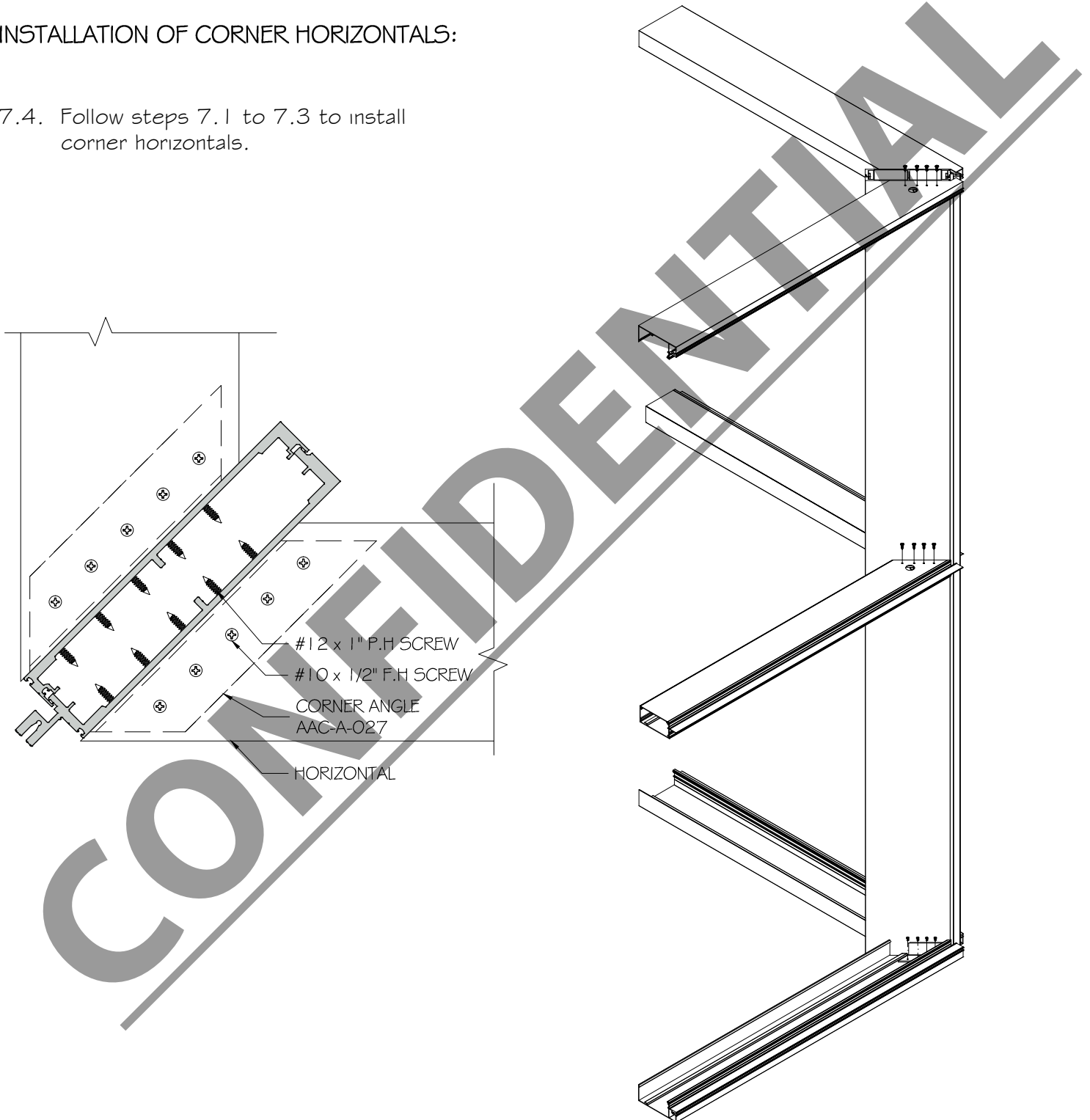

DETAIL 7.4

STEP 8

INSTALL ANCHOR SCREWS AND HORIZONTAL COVERS:

8.1. Install the anchor screw specified in the shop drawings as shown in detail.

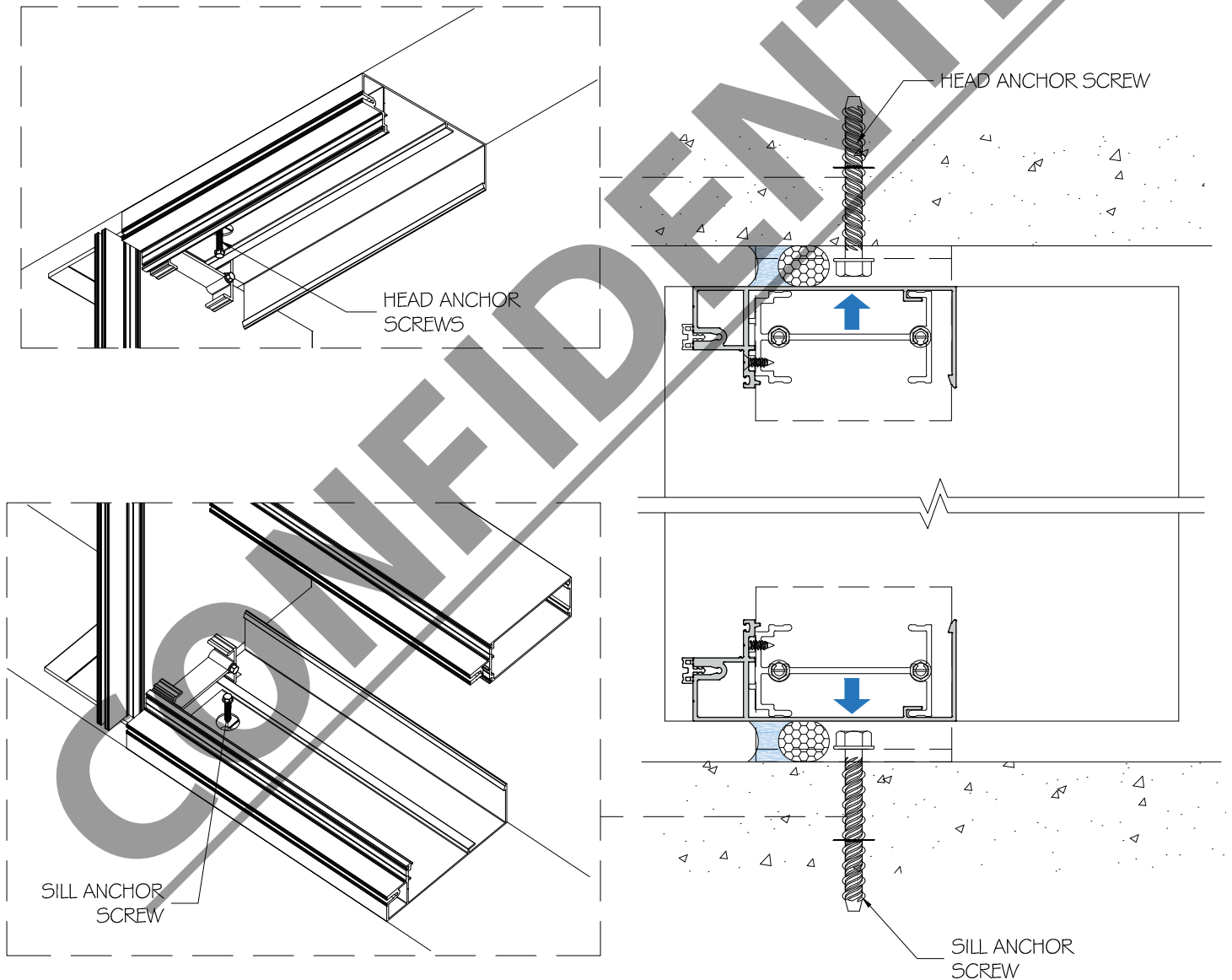

DETAIL 8.1.

- 8.2. Verify covers fabrications for the corner angle and the length of the part specified in the shop drawings.
- 8.3. Install the open horizontal covers as shown in detail.

HORIZONTAL COVER

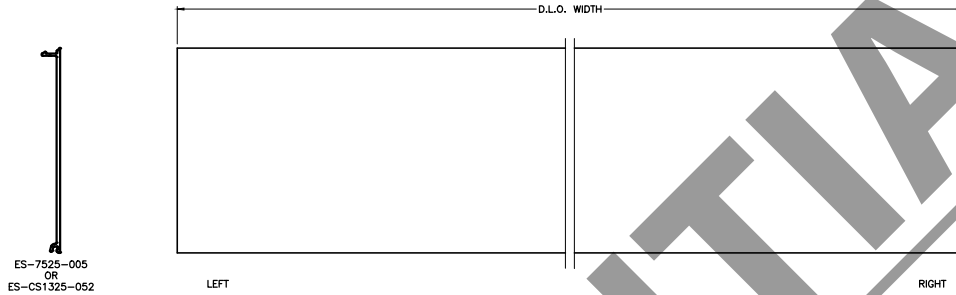

CORNER HORIZONTAL COVER

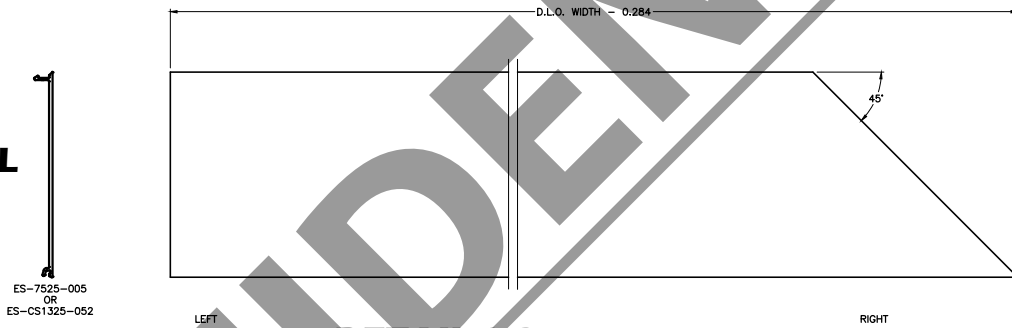

DETAIL 8.2.

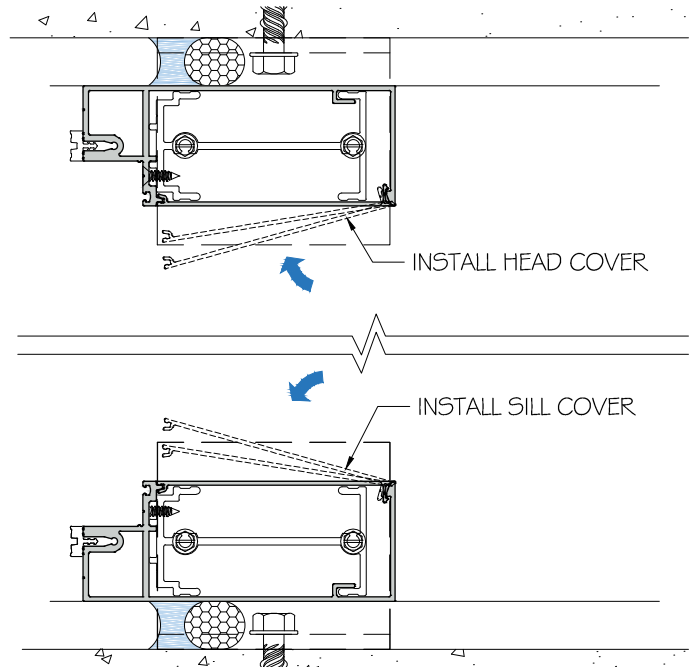
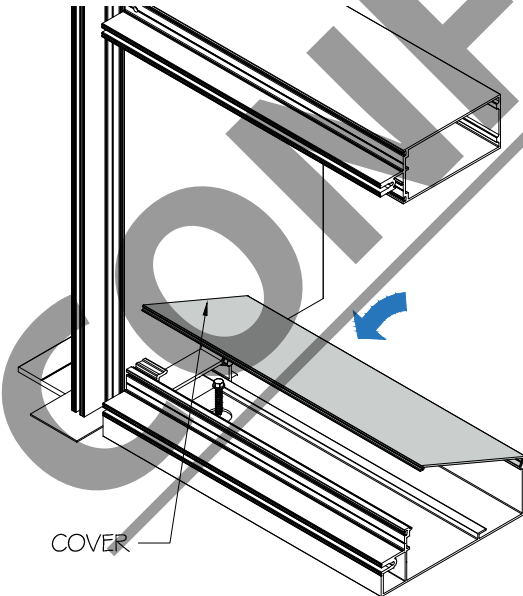

DETAIL 8.3.

STEP 9

INSTALL CORNER ADAPTOR:

- 9.1. Verify the fabrications for the corner adaptor.
- 9.2. Verify the gaskets are already installed. If not install.
- 9.3. Prior to installing the corner adaptor, fill with silicone D.C. 791 the verticals reglets as shown in detail 9.3.
- 9.4. Install the corner adaptor with the required screw.
- 9.5. Install the end cap and caulk the joint.

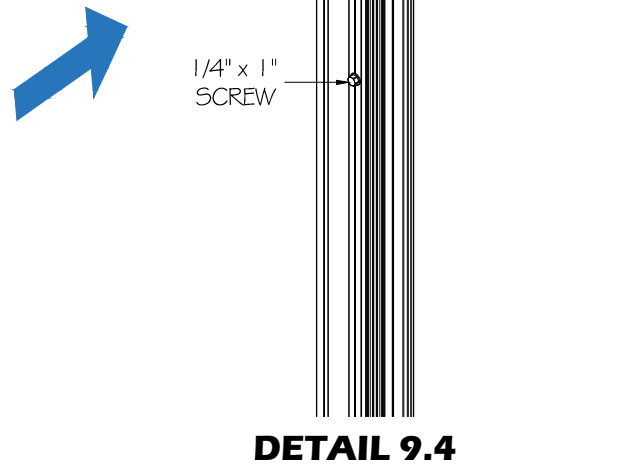
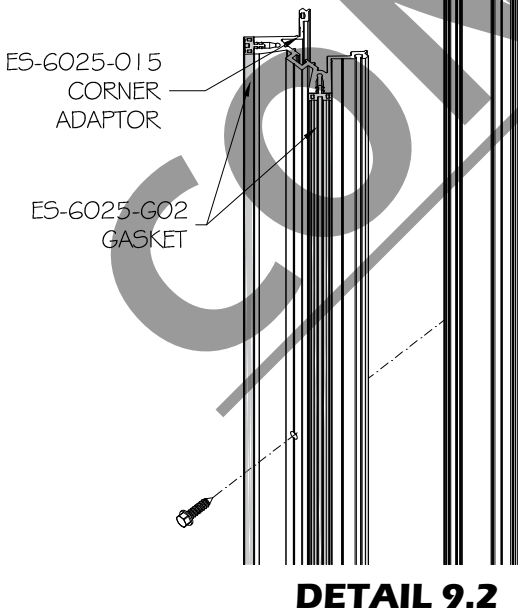
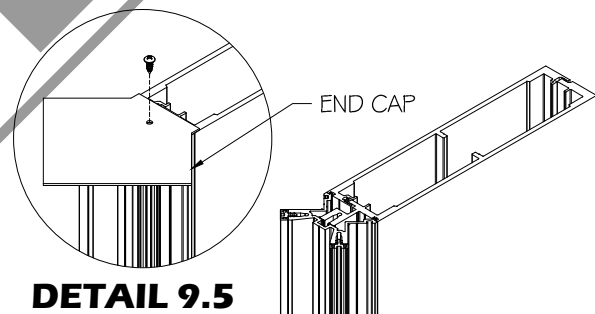
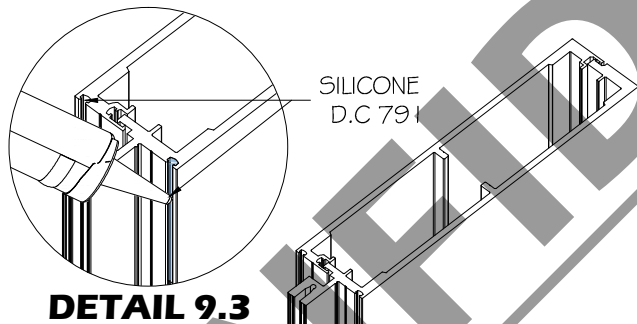
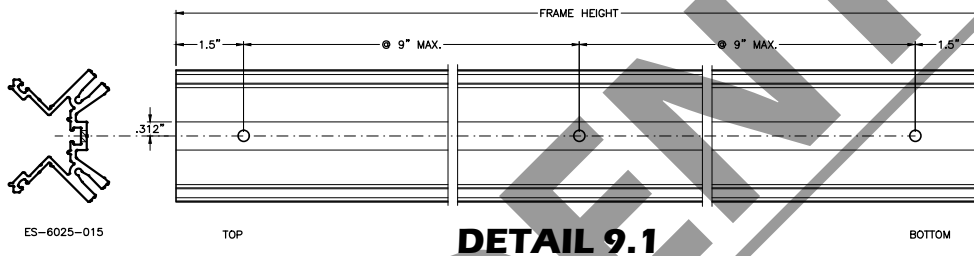

STEP 10

INSTALL THE POCKET FILLER:

- 10.1. Verify the length of the pocket filler in the shop drawings.
- 10.2. Prior to installing the pocket filler caulk the joint between the mullions as shown in detail 10.2.
- 10.3. Install the jamb pocket filler as shown in detail.

POCKET FILLER FOR LAMINATED GLASS

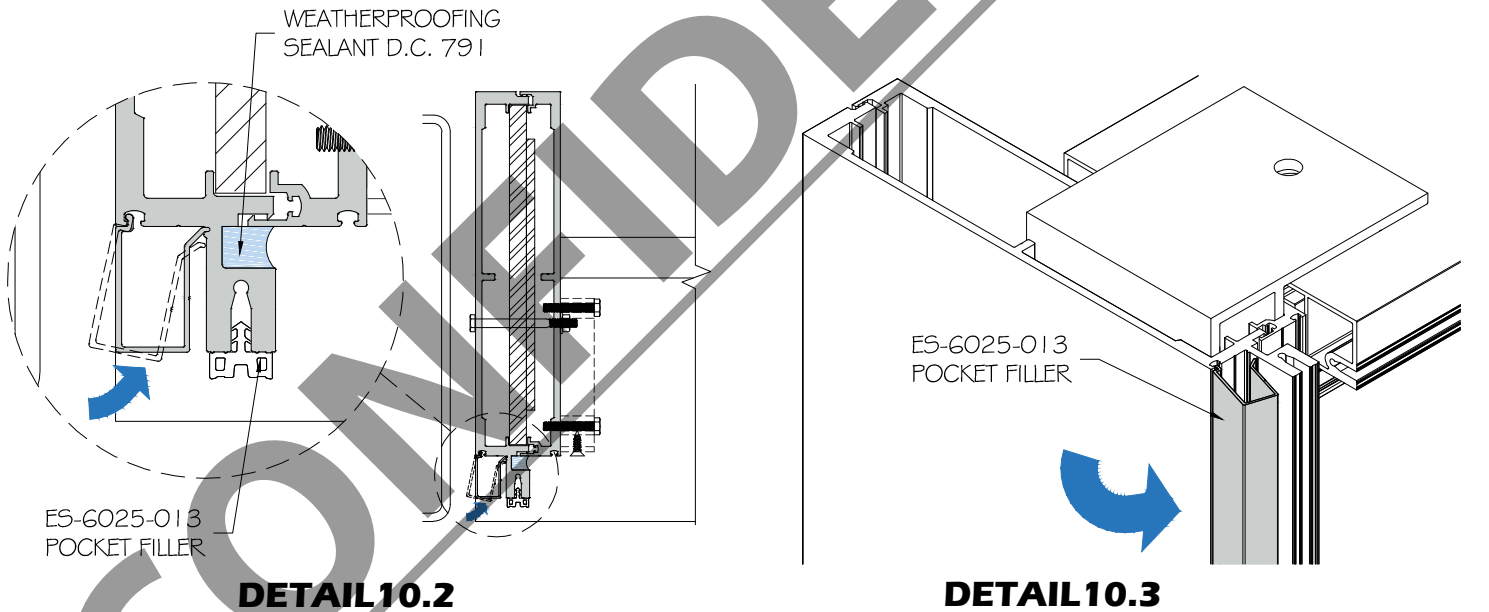

STEP 11

GLAZING:

- 11.1. Prior to installing setting blocks apply silicone D.C. 791 to secure them in place.
- 11.2. Install setting blocks, sides blocks and bumpers as shown in detail.



Preparation: before glazing process clean carefully all the profiles surfaces that will be in contact with silicone using isopropyl alcohol and two-rag method.

Make sure that the profile surface it's clean and dry before applying the sealant. Apply required primer if necessary.

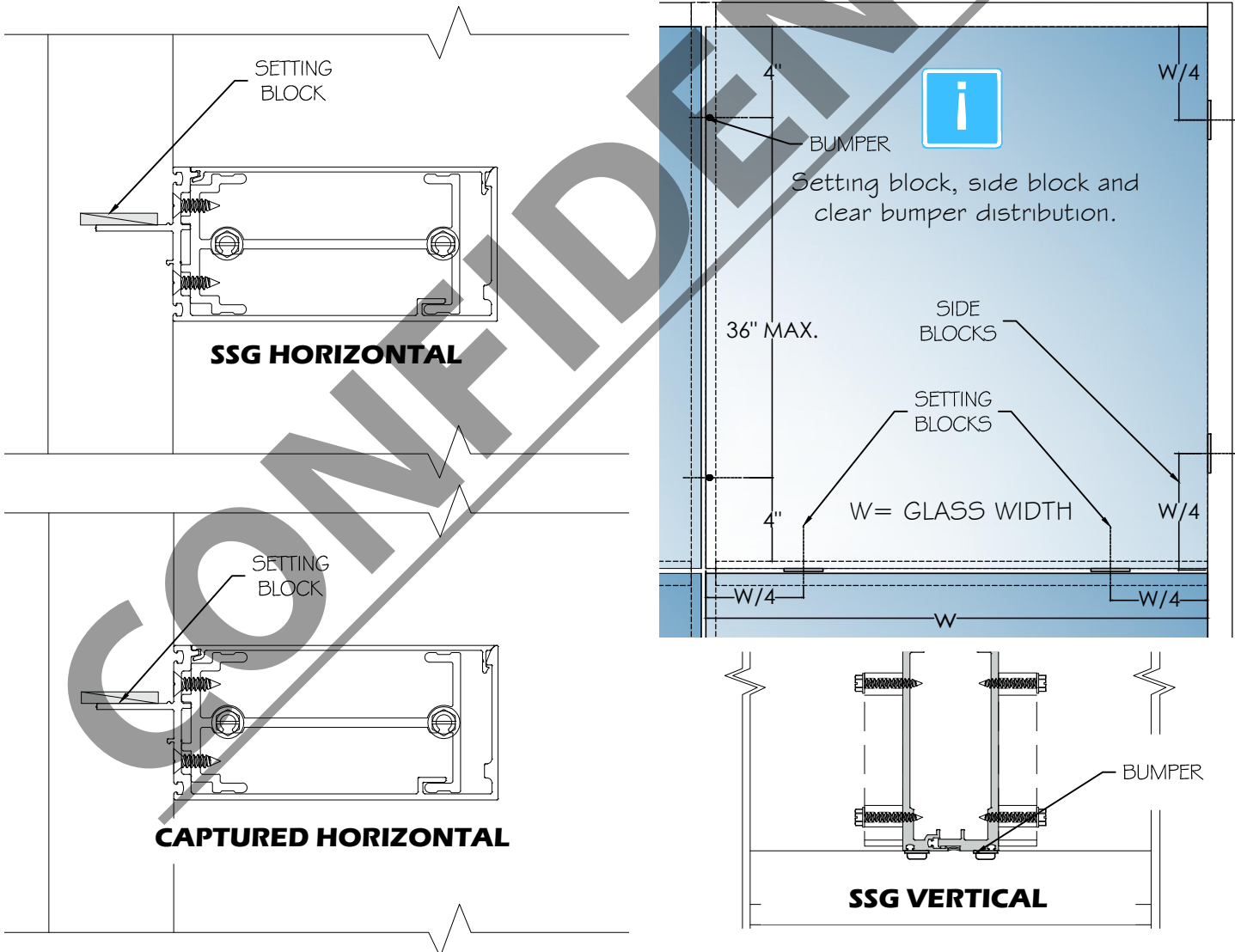

DETAIL 11.2

11.3. Apply silicone D.C. 791 to contact surfaces, then install joint plugs (ES-6025-B10) between verticals and horizontals (DETAIL A). Seal joint plugs surface as shown detail (DETAIL B).

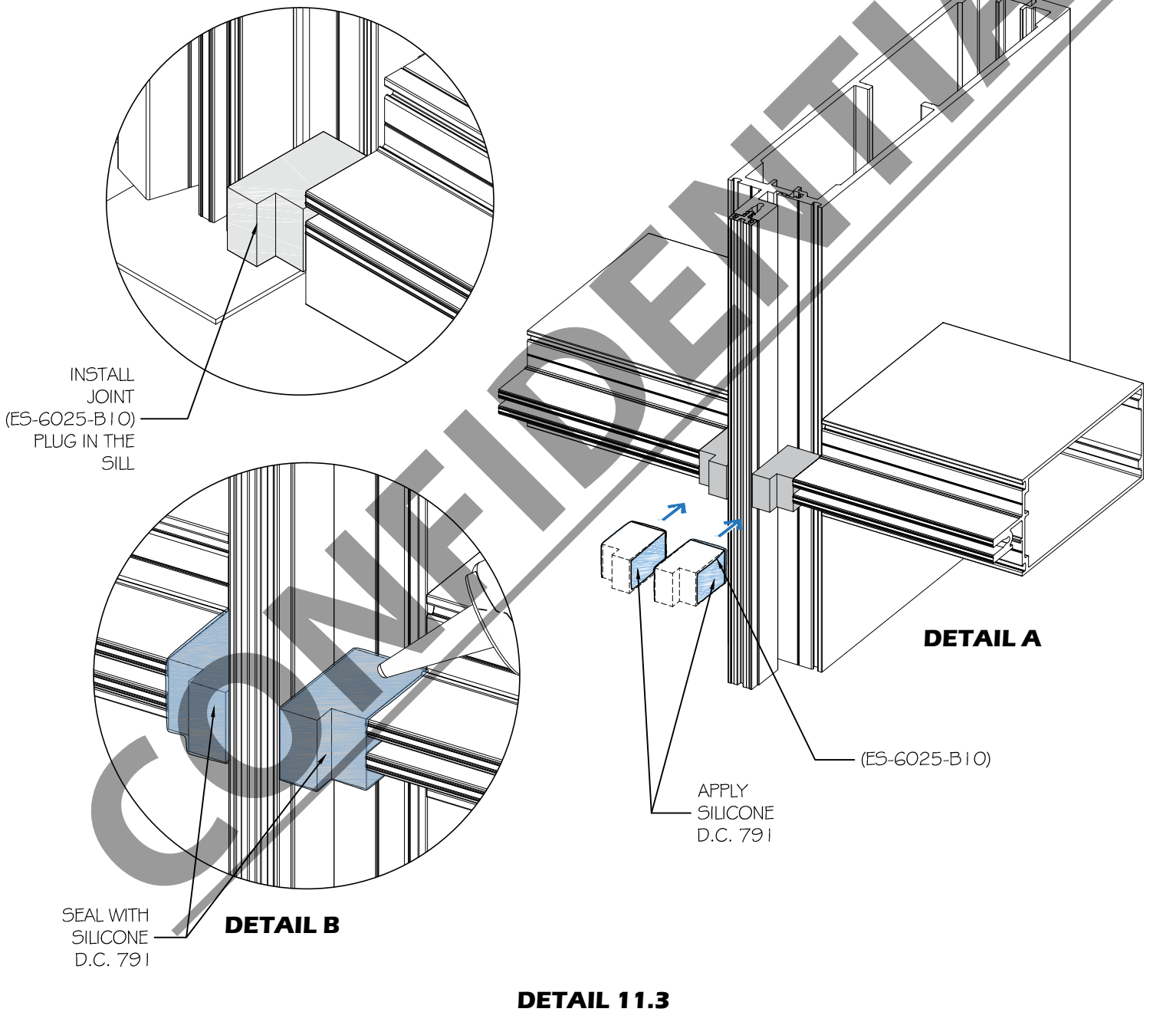

- 11.4. Verify if the isolator gasket is already installed, then install 1/4" x 1/4" foam tape as shown in detail.
- 11.5. Place glass carefully with required equipment and man power to manage the glass properly and safely.

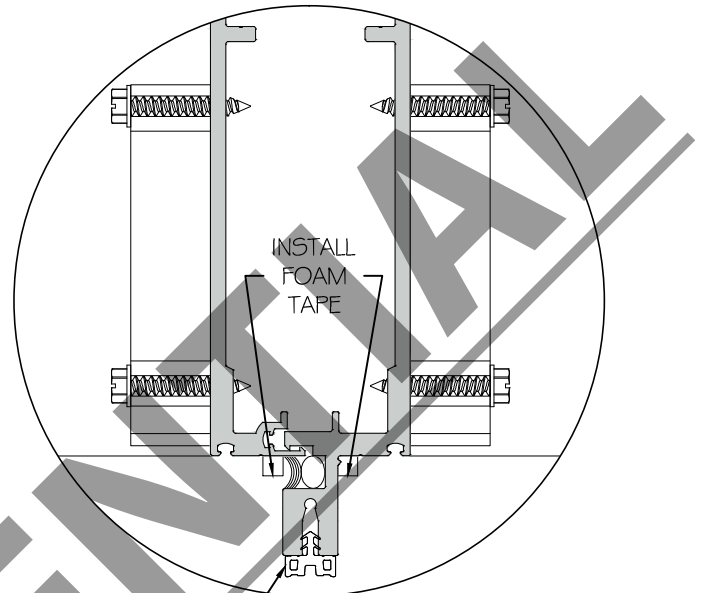
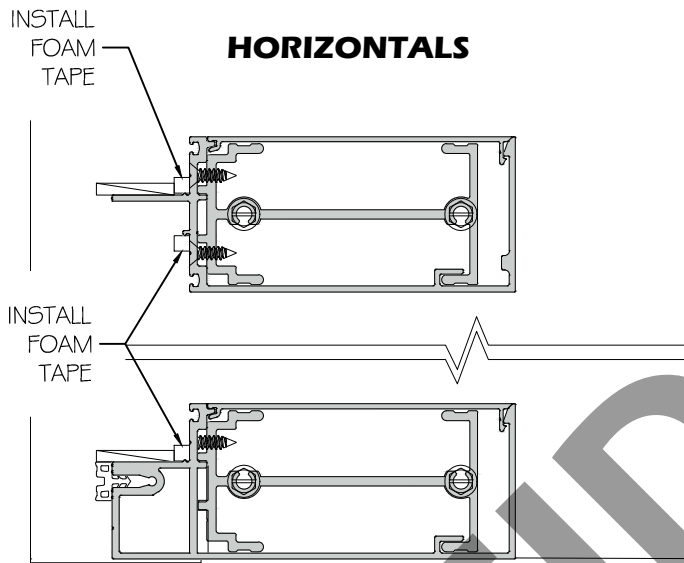

HORIZONTAL (CAPTURED)

HORIZONTAL (SSG)

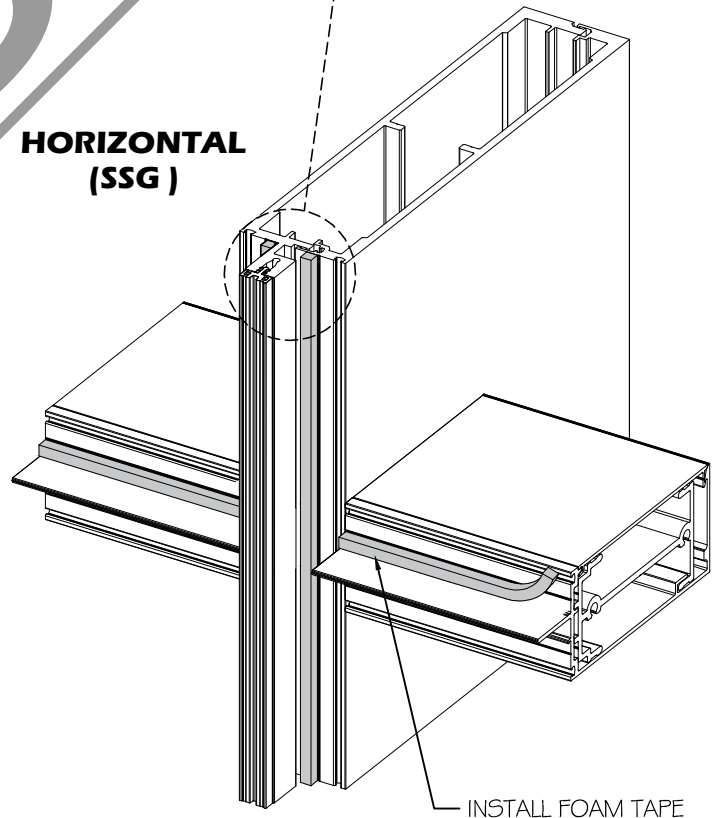
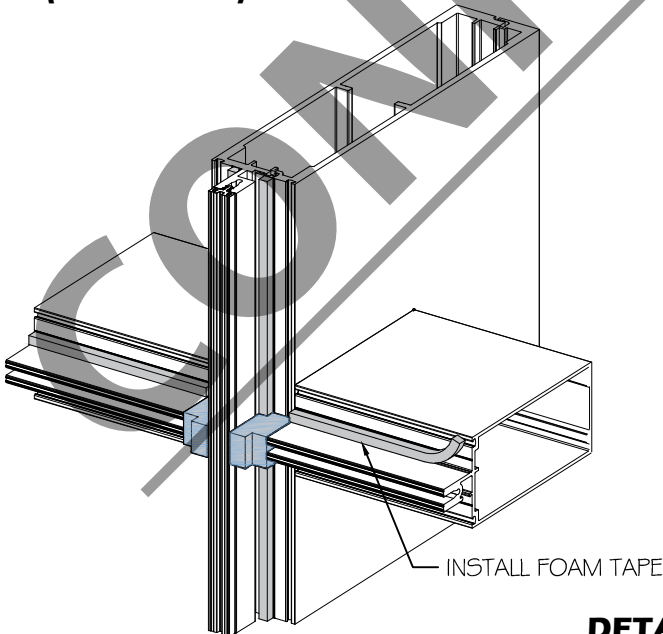

DETAIL 11.4

- 11.6. Verify the shop drawings to identify the pressure plate reference to use and its locations.
- 11.7. Check the shop drawings to verify the length of the part.
- 11.8. Verify pressure plates fabrications as shown in detail (A). Spacing between vertical and horizontal pressure plates should be of 1/8"(B).

VERTICAL PRESSURE PLATE

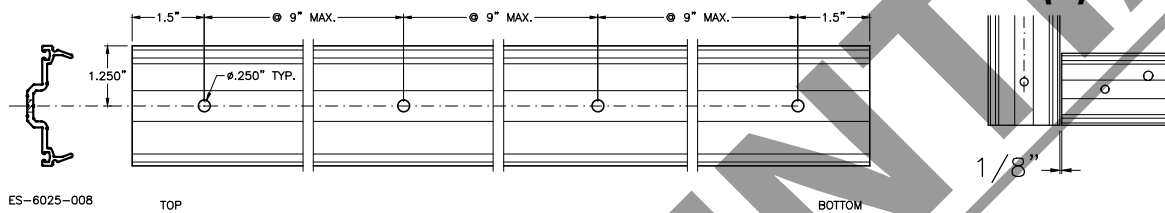

DETAIL 11.8 (B)

HORIZONTAL PRESSURE PLATE

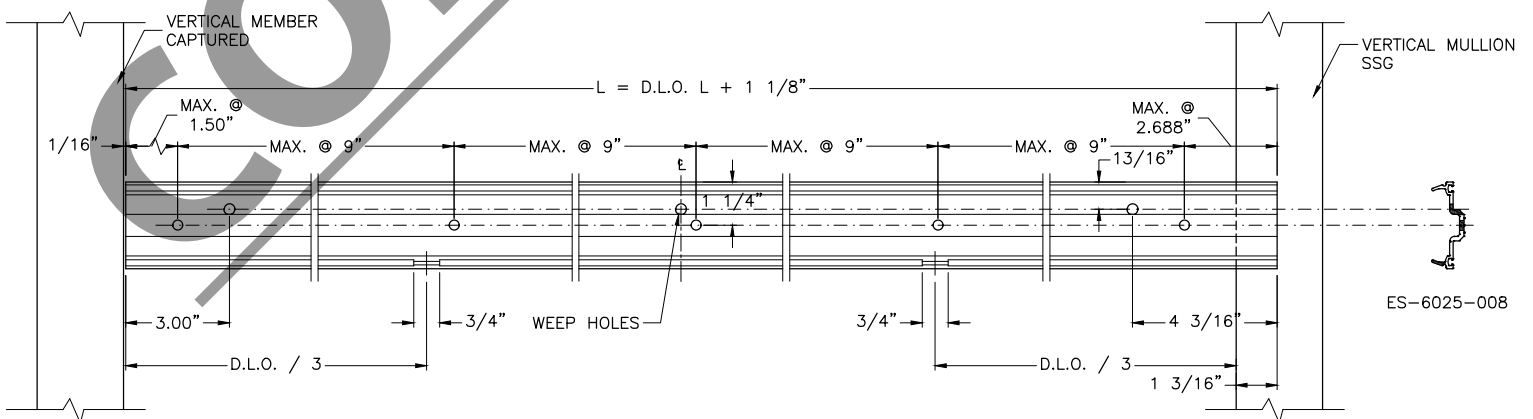
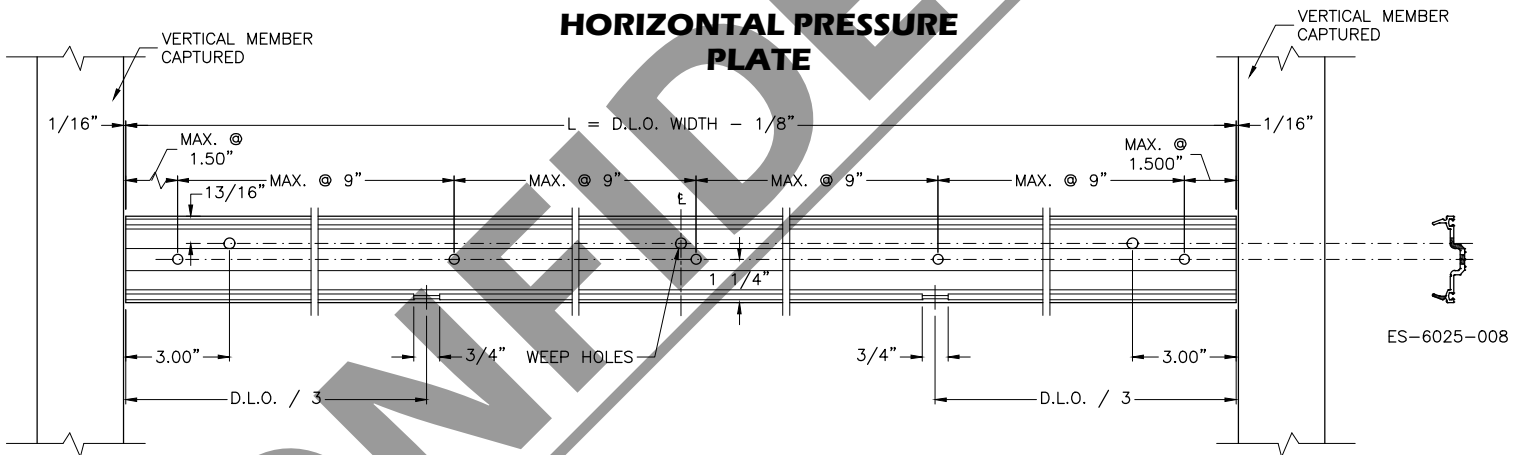

DETAIL 11.7 (A)

11.9. For captured configurations install glass considering glass bite shown in detail (11.9) and secure with 4" pressure plates at 3" from glass edges.



Glass bite may vary depending on the glazing configurations. Verify shop drawings to determine the glass bite.

11.10. Prior to installing final pressure plates, Verify exterior gaskets as shown in detail.



For jambs verify shop drawings to determine if it is required double sided tape installation as shown in detail.

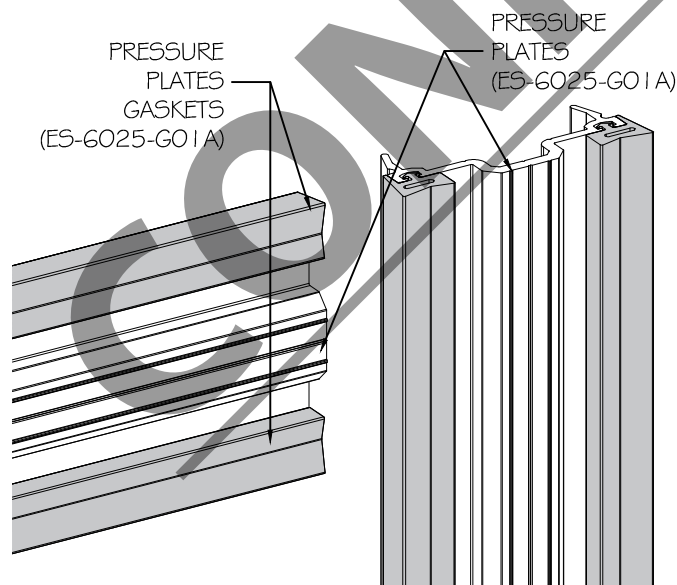
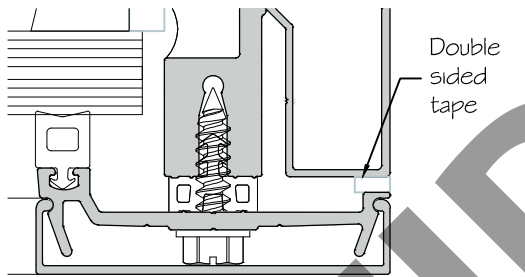

DETAIL 11.10

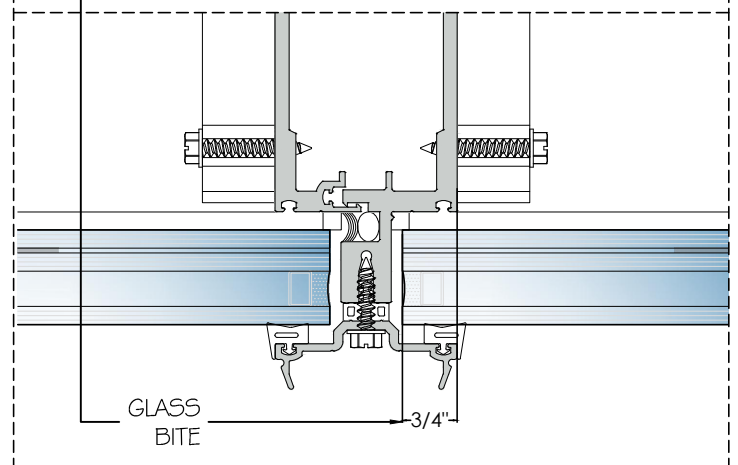
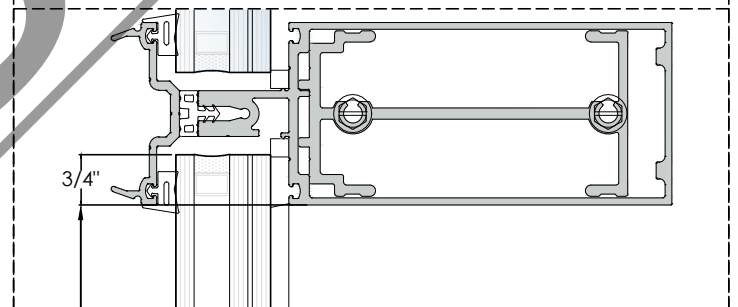
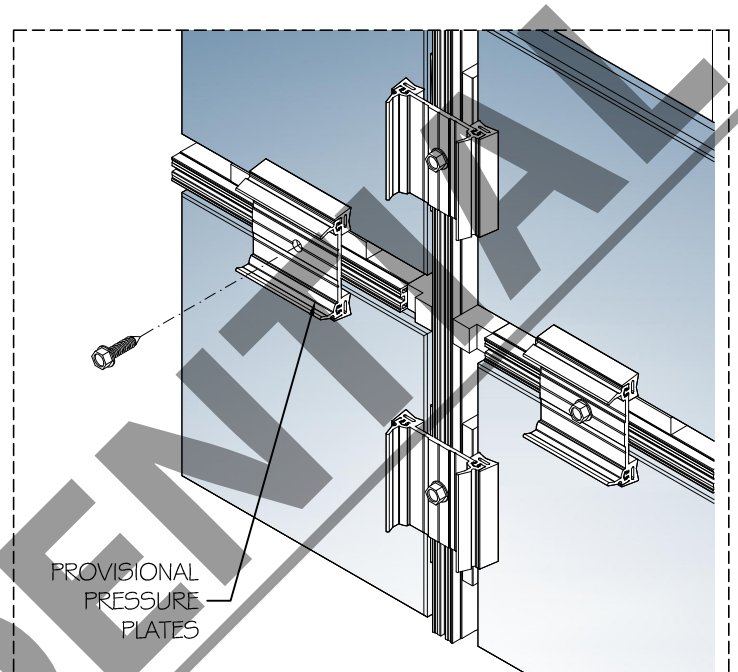

DETAIL 11.9

11.11. Install the vertical pressure plates from bottom to top, and the horizontals starting at the center and working towards the end bays.

11.12. Apply sealant (D.C. 791) to the head of the screws and to the joints.

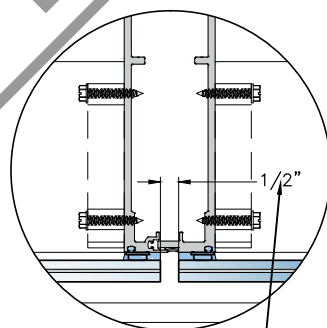
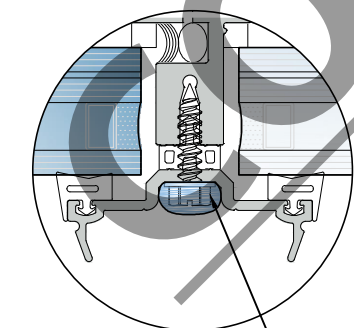
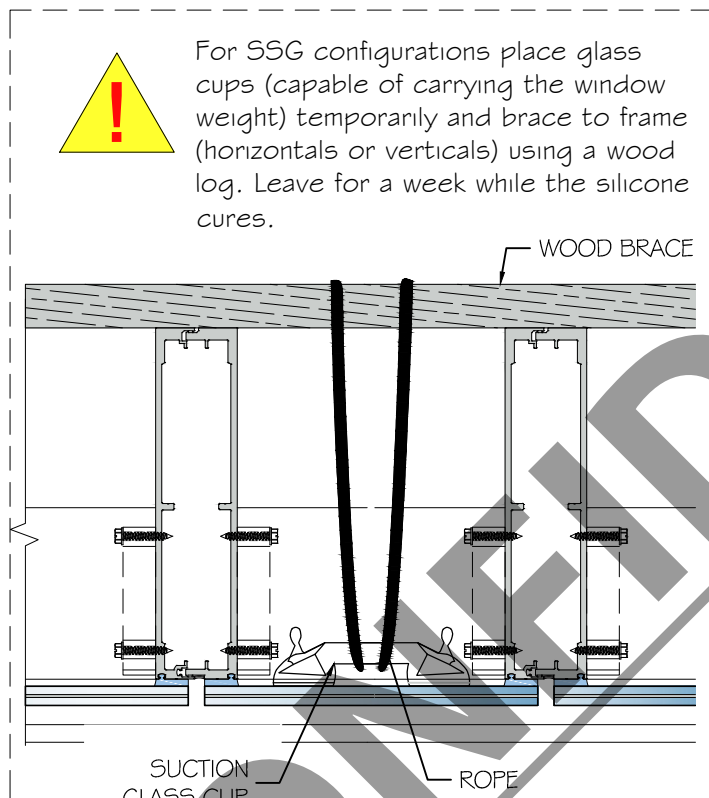

DETAIL 11.12

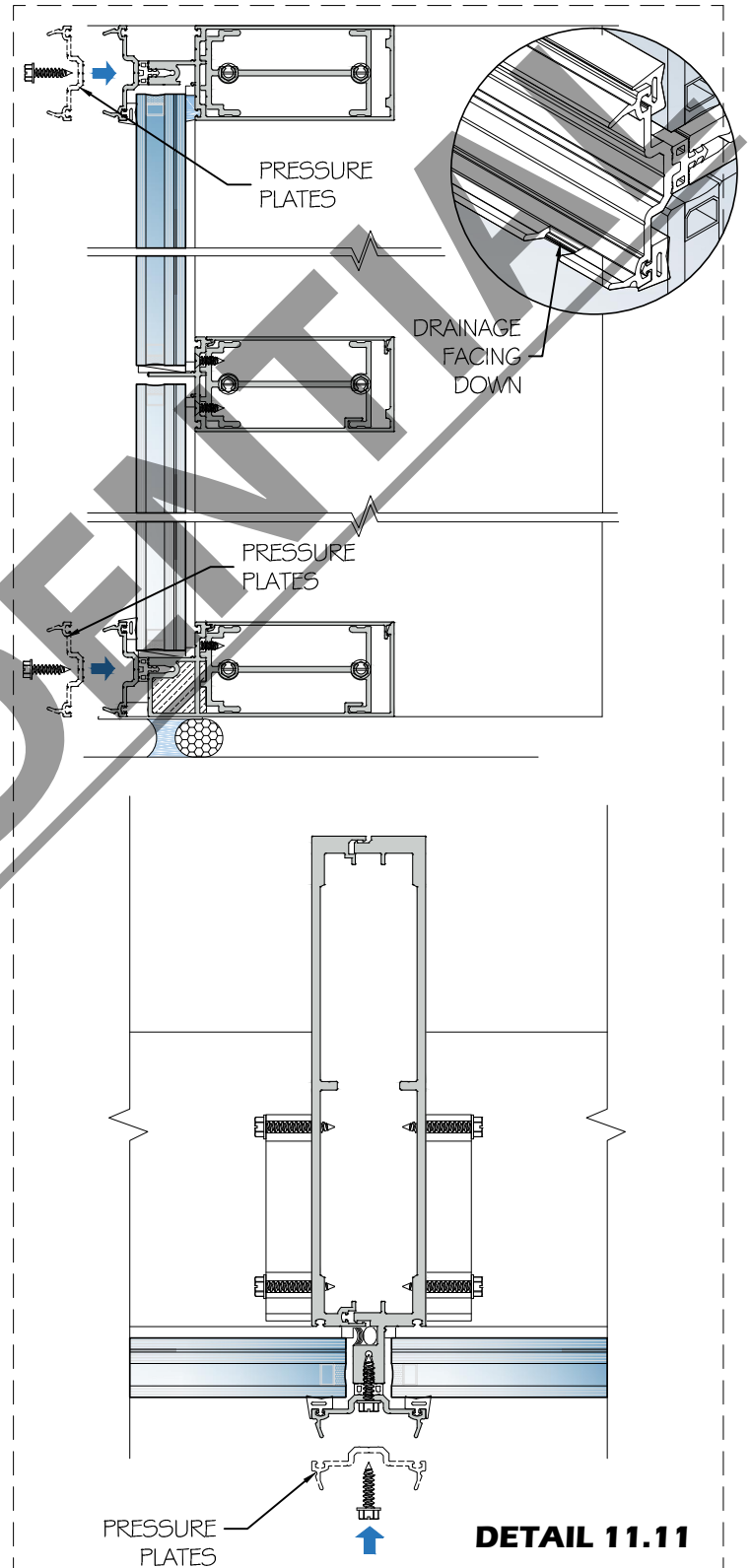

11.13. Use masking tape to protect glass and metal from fresh silicone. Remove it when the process is finished.

11.14. Caulk glass perimeter as shown in detail.

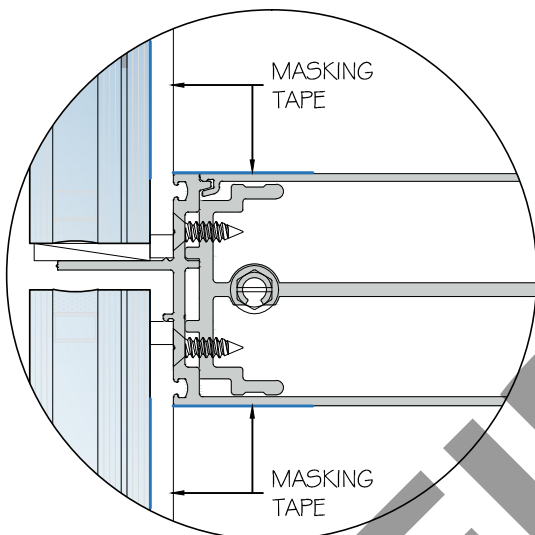

DETAIL 11.13

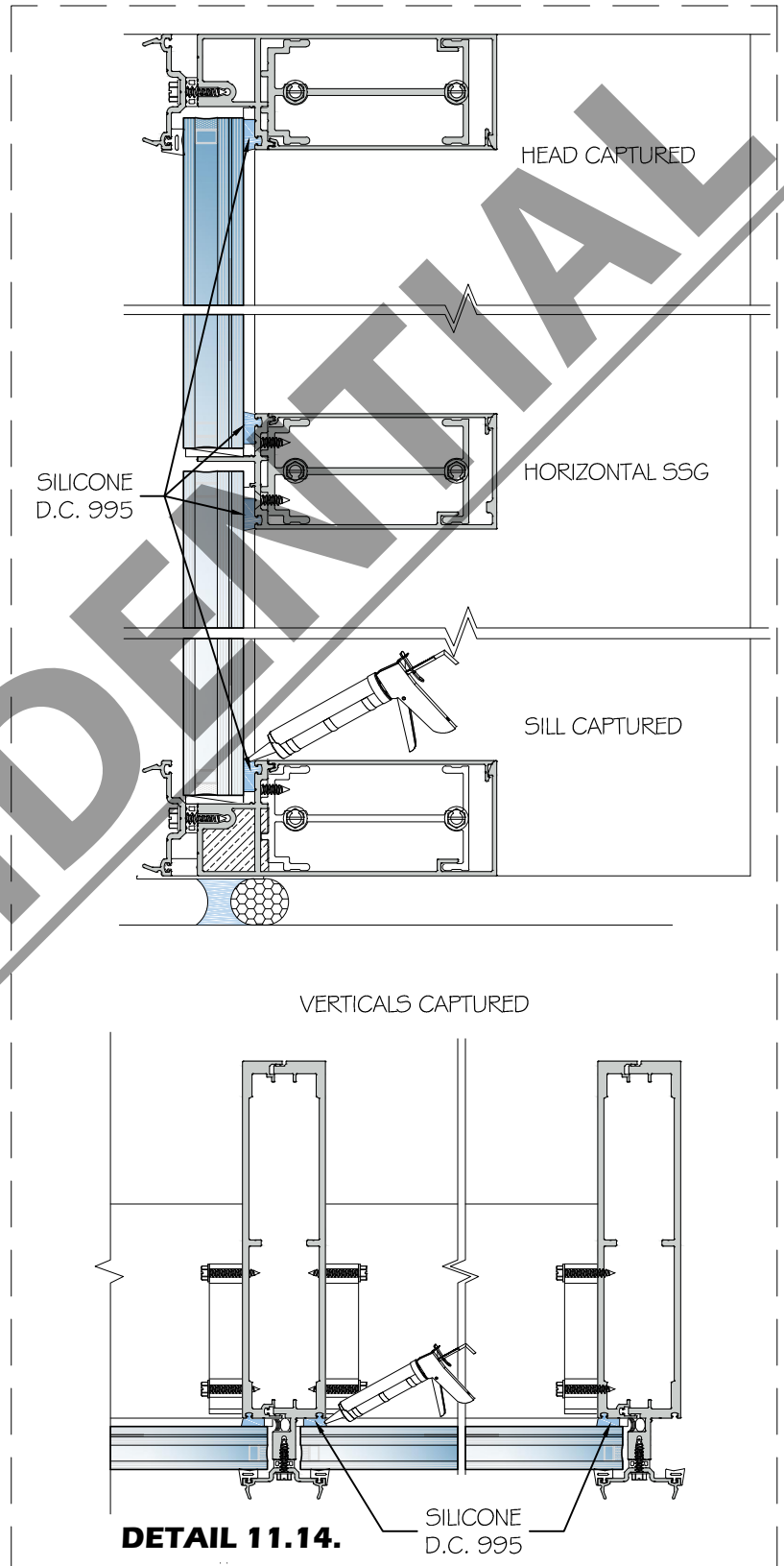

DETAIL 11.14.

11.15. Verify shop drawings to identify the covers reference to use and its locations.

11.16. Check the shop drawings to verify the length of the part.

11.17. Spacing between vertical and horizontal covers should be 1/16".

VERTICAL COVER

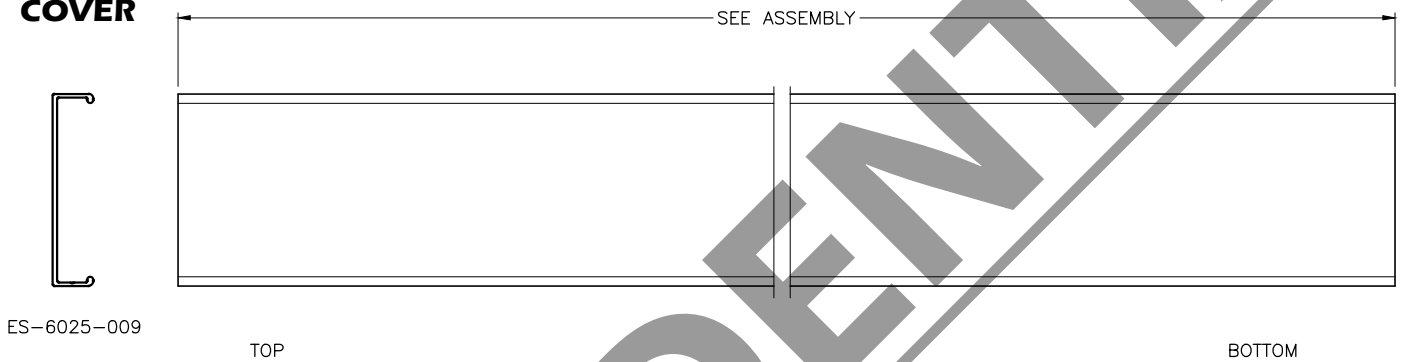

DETAIL 11.15

HORIZONTAL COVER

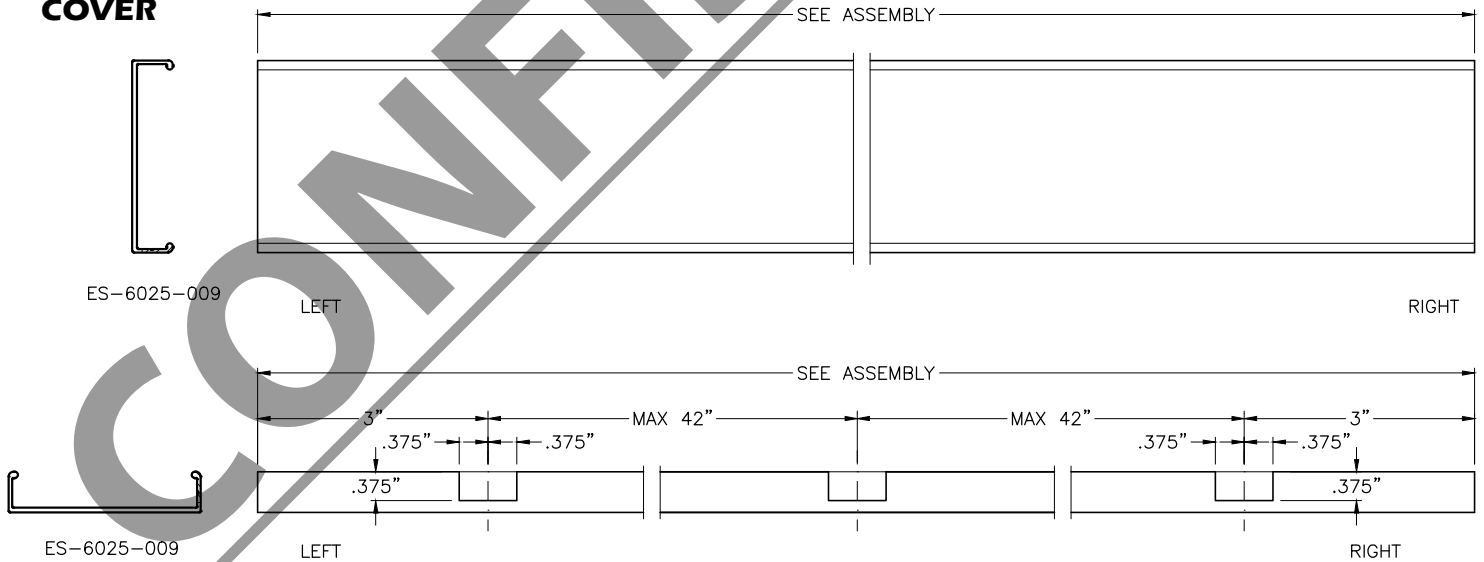

DETAIL 11.16

- 11.18. Install covers in captured verticals and horizontals with the help of a wood block and a mallet.

Covers must be centered with a 1/16" spacing from vertical covers on each side.

- 11.19. For SSG configuration insert backer rods and apply silicone D.C.791 to perimeter.

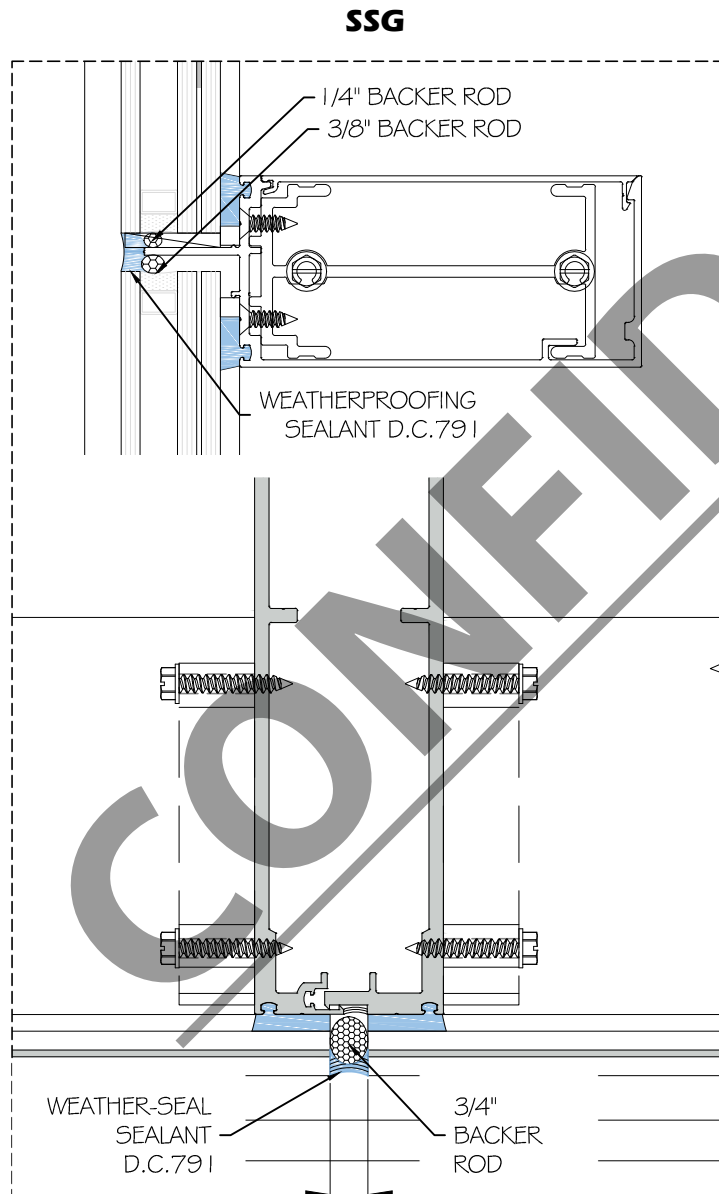

DETAIL 11.19

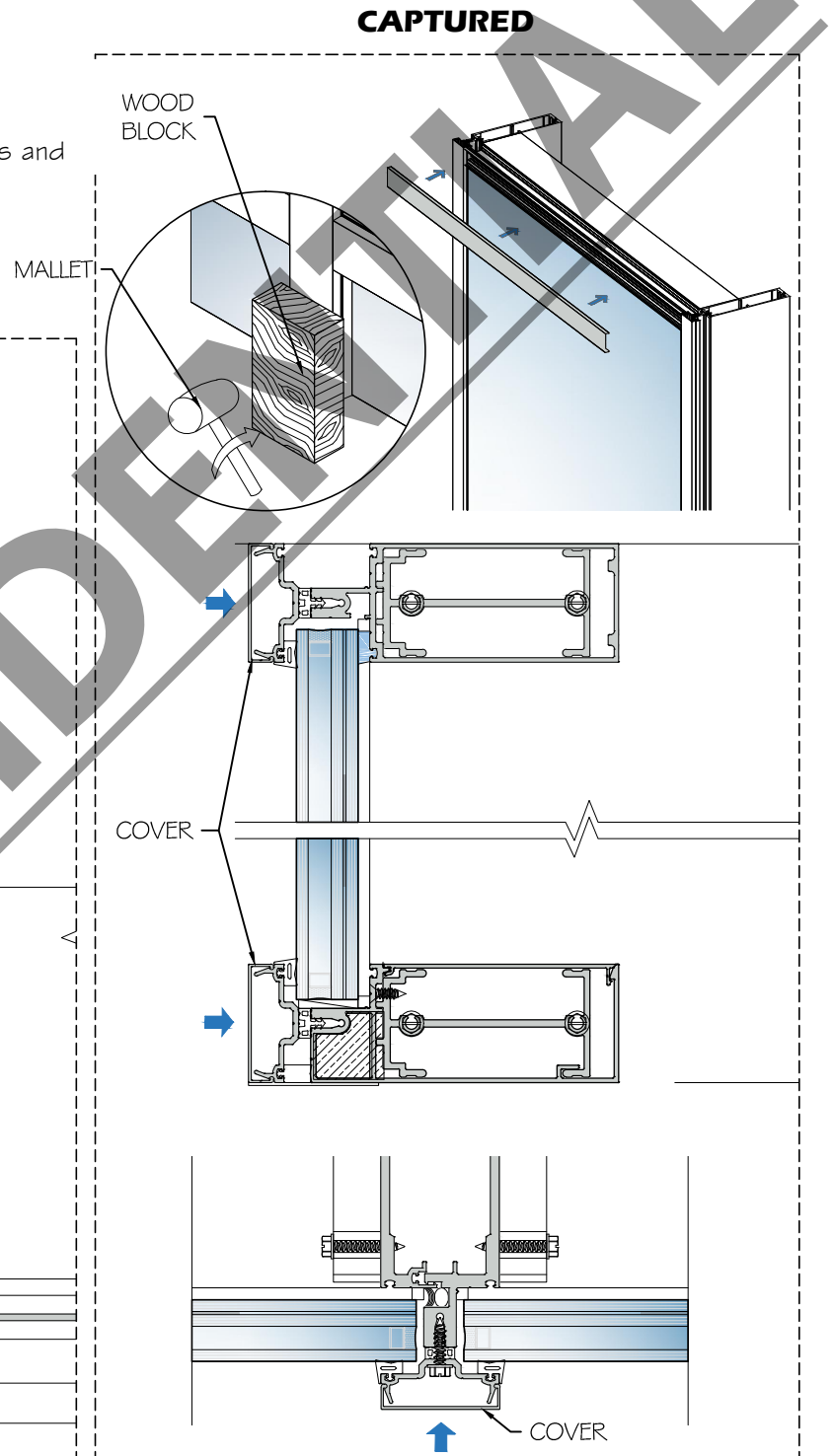

DETAIL 11.18

11.20. Place splice sleeve at covers joints as shown in detail. For verticals SSG and horizontal captured joints must be 1/2" width.

11.21. Caulk joints between vertical and horizontal pressure plates.

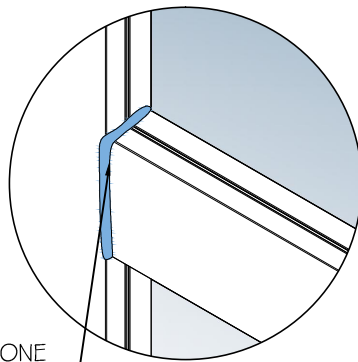
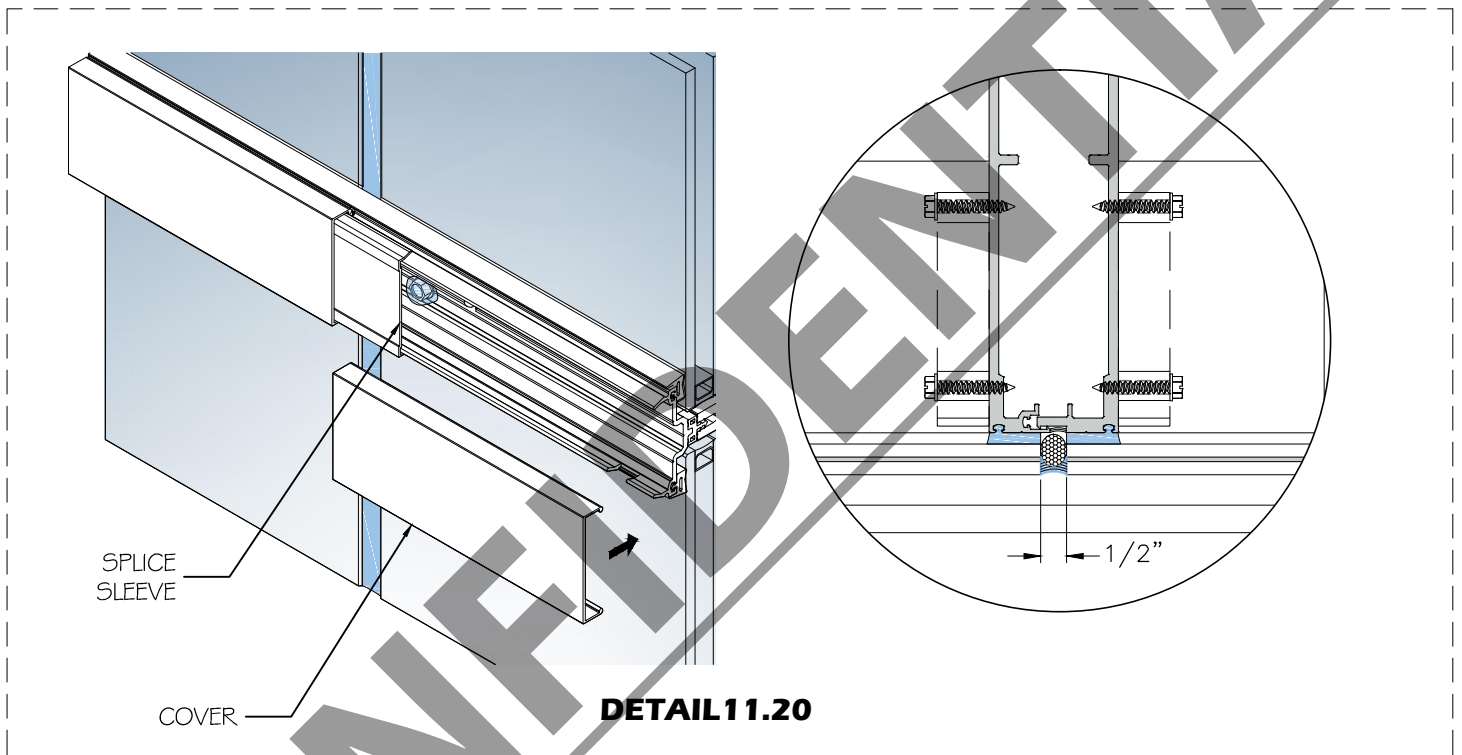

SILICONE
D.C.791 @
JOINTS

DETAIL 11.21

STEP 12

SEAL PERIMETER:

12.1. Insert backer rod and apply Weatherproofing sealant D.C 791 per approved shop drawings.

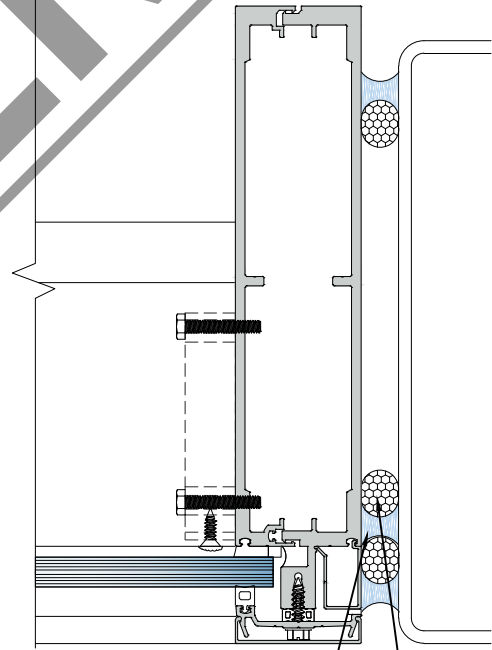
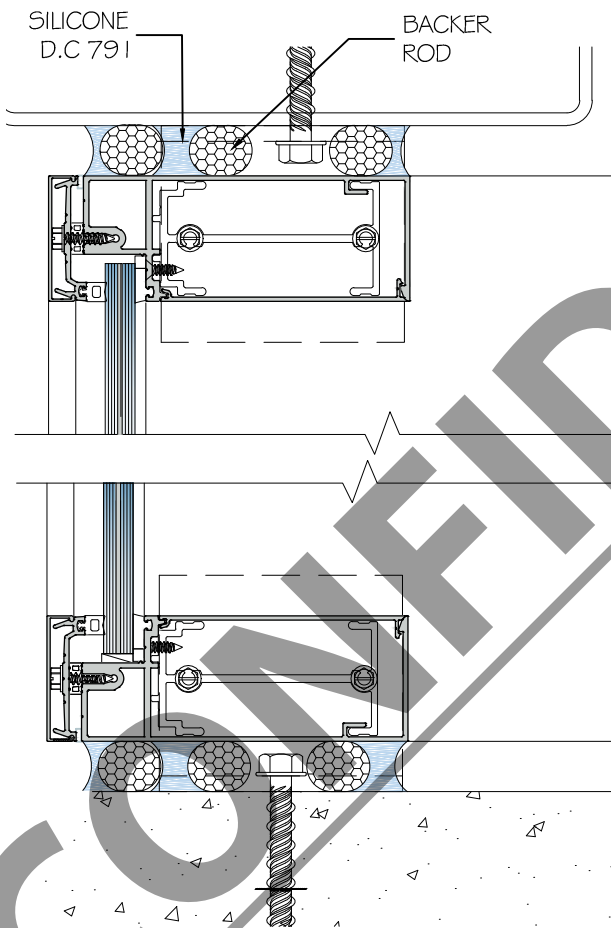

SILICONE
D.C 791

BACKER
ROD

DETAIL 12.1

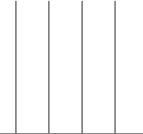

REVISIÓN No.	FECHA	DESCRIPCIÓN	PAG.
△			
△			
△			
△			
△			
△			
△			
△			
△			
△			

CONFIDENTIAL

ENERGÍA SOLAR ESWINDOWS

**Av. Circunvalar at 100 mts of Via 40 Las Flores
Barranquilla, Colombia PBX: (57 5) 3664600
service@eswllc.com, PBX: (+1) 305 5074545**

ELABORADO POR SARIEL GONZALEZ